

Golden DRAGON Plus

无铅设计, 符合 RoHS 标准

Lead (Pb) Free Product - RoHS Compliant

LD W5AM, LB W5AM, LT W5AM



初步数据 / Preliminary Data

特点

- **封装:** 白色 SMD 封装, 无色透明硅树脂透明硅树脂透镜
- **典型光通量:** 442 mW (深蓝色)、27 lm (蓝色)、87 lm (真绿色) (工作电流为350 mA 时); 最大 971mW (深蓝色)、54 lm (蓝色)、165 lm (真绿色) (工作电流为 1 A 时)
- **装置特点:** 小尺寸高效光源
- **波长:** 455 nm (深蓝色)、470 nm (蓝色)、528 nm (真绿色)
- **视角:** 170°
- **技术:** ThinGaN
- **光效:** 37% (深蓝色)、34 lm/W (蓝色)、128 lm/W (真绿色) (工作电流为 100 mA 时)
- **分组参数:** 光通量、波长、辐射功率
- **组装方式:** 适用于所有表面封装方式
- **焊接方式:** 回流焊接
- **预处理:** 符合 JEDEC 4 级标准
- **卷带封装:** 24 mm 卷带, 200/卷, 直径为 180 mm
- **ESD 耐压:** ≥ 2 kV (符合 JESD22-A114-D 标准)

应用

- 用于大幅面电视屏的 TFT 背光照明
- 背光照明 (LCD、开关、显示器、广告灯光、普通照明)
- 取代微型白炽灯
- 标志灯 (如台阶灯、出口通道灯等)
- RGB – 频闪灯
- 信号灯和符号灯
- 扫描仪

Features

- **Package:** white SMD package, colorless clear silicone resin, clear silicone lens
- **Typical Luminous Flux:** 442 mW (deep blue); 27 lm (blue); 87 lm (true green) at 350 mA up to 971 mW (deep blue); 54 lm (blue); 165 lm (true green) at 1 A
- **Feature of the device:** high efficient lightsource at low space
- **Wavelength:** 455 nm (deep blue), 470 nm (blue), 528 nm (true green)
- **Viewing angle:** 170°
- **Technology:** ThinGaN
- **Optical efficiency:** 37 % (deep blue), 34 lm/W (blue), 128 lm/W (true green) at 100 mA
- **Grouping parameter:** luminous flux, wavelength, radiant power
- **Assembly methods:** suitable for all SMT assembly methods
- **Soldering methods:** Reflow soldering
- **Preconditioning:** acc. to JEDEC Level 4
- **Taping:** 24-mm tape with 200/reel, $\varnothing 180$ mm
- **ESD-withstand voltage:** up to 2 kV acc. to JESD22-A114-D

Applications

- TFT backlighting for large area TV applications
- backlighting (LCD, switches, displays, illuminated advertising, general lighting)
- Substitution of micro incandescent lamps
- Marker lights (e.g. steps, exit ways, etc.)
- RGB - strobe light
- Signal and symbol luminaire
- Scanners

订购信息
Ordering Information

类型 Type	发光颜色 Color of Emission	辐射功率 ^{第 20 页 1)} Radiant Power ^{1) page 20} $I_F = 350 \text{ mA}$ $\Phi_E \text{ (mW)}$	订购代码 Ordering Code
LD W5AM-3T3U-35	深蓝色/ deep blue	355 ... 630	Q65110A8621

订购信息
Ordering Information

类型 Type	发光颜色 Color of Emission	光通量 ^{第 20 页 1)} Luminous Flux ^{1) page 20} $I_F = 350 \text{ mA}$ $\Phi_V \text{ (lm)}$	发光强度 ^{第 20 页 2)} Luminous Intensity ^{2) page 20} $I_F = 350 \text{ mA}$ $I_V \text{ (mcd)}$	订购代码 Ordering Code
LB W5AM-GYHY-25	蓝色/ blue	21.000 ... 39.000	10.500 (典型值) / (typ.)	Q65110A8620
LT W5AM-JYKZ-36	真绿色/ true green	52.000 ... 112.000	28.700 (典型值) / (typ.)	Q65110A8619

注释： 上述类型编号代表仅包含几个亮度组的订购组（详细说明请参见第 7 页）。每个卷盘上仅装运一个亮度组（一个卷盘上不会混装两个亮度组）。例如，LB W5AM-GXHX-25 表示任何一个卷盘上仅可装运一个亮度组：GX、GY、GZ 或 HX。

为了确保可用性，单个亮度组将不接受订购。

类似地，对于需要测量和分选波长组的颜色，每个卷盘上将仅装运一个波长组。例如，LB W5AM-GXHX-25 表示仅可装运一个波长组：2、3、4 或 5。为了确保可用性，单个波长组将不接受订购（详细说明请参见第 6 页）。

Note: The above Type Numbers represent the order groups which include only a few brightness groups (see page 7 for explanation). Only one group will be shipped on each reel (there will be no mixing of two groups on each reel). E.g. LB W5AM-GXHX-25 means that only one group GX, GY, GZ or HX will be shippable for any one reel. In order to ensure availability, single brightness groups will not be orderable.

In a similar manner for colors where wavelength groups are measured and binned, single wavelength groups will be shipped on any one reel. E.g. LB W5AM-GXHX-25 means that only 1 wavelength group -2,-3, -4, or -5 will be shippable. In order to ensure availability, single wavelength groups will not be orderable (see page 6 for explanation).

相关表
Correlation Table

类型 Type	辐射功率 ^{第 20 页 1)} Radiant Power ^{1) page 20} $I_F = 350 \text{ mA}$ $\Phi_E \text{ (mW)}$	典型辐射功率 ^{第 20 页 2)} Typical Radiant Power ^{2) page 20} $I_F = 400 \text{ mA}$ $\Phi_E \text{ (mW)}$
LD W5AM-3T3U-35	355 ... 630	630

相关表
Correlation Table

类型 Type	光通量 ^{第 20 页 1)} Luminous Flux ^{1) page 20} $I_F = 350 \text{ mA}$ $\Phi_V \text{ (lm)}$	典型光通量 ^{第 20 页 2)} Typical Luminous Flux ^{2) page 20} $I_F = 400 \text{ mA}$ $\Phi_V \text{ (lm)}$
LB W5AM-GYHY-25	21.000 ... 39.000	38.400
LT W5AM-JYKZ-36	52.000 ... 112.000	108.000

最大额定值
Maximum Ratings

参数 Parameter	符号 Symbol	值 Values	单位 Unit
工作温度范围 Operating temperature range	T_{op}	- 40 ... + 110	°C
存储温度范围 Storage temperature range	T_{stg}	- 40 ... + 110	°C
结点温度 Junction temperature	T_j	125	°C
正向电流(环境温度25°C) Forward current ($T_A = 25^\circ\text{C}$)	I_F I_F	100 1000	mA mA
脉冲电流 Surge current $t \leq 10 \mu\text{s}, D = 0.005, T_A = 25^\circ\text{C}$	I_{FM}	2000	mA
反向电压 Reverse voltage ($T_A = 25^\circ\text{C}$)	V_R	不设计用于反向运行 not designed for reverse operation	V

特性

Characteristics

 $(T_A = 25\text{ }^\circ\text{C})$

参数 Parameter	符号 Symbol	值 Values			单位 Unit
		LD	LB	LT	
峰值波长 Wavelength at peak emission $I_F = 350\text{ mA}$ (典型值) / (typ.)	λ_{peak}	449	465	520	nm
主波长 ^{第 20 页 3)} Dominant wavelength ^{3) page 20} $I_F = 350\text{ mA}$ (最小值) / (min.) (典型值) / (typ.) (最大值) / (max.)	λ_{dom}	449 455* 461	464 470* 476	513 528* 537	nm
50 % $\Phi_{\text{rel max}}$ 时的光谱带宽 Spectral bandwidth at 50 % $\Phi_{\text{rel max}}$ $I_F = 350\text{ mA}$ (典型值) / (typ.)	$\Delta\lambda$	25	25	33	nm
50% I_V 时的全视角 Viewing angle at 50 % I_V (典型值) / (typ.)	2φ	170	170	170	度 deg.
正向电压 ^{第 20 页 4)} Forward voltage ^{4) page 20} $I_F = 350\text{ mA}$ (最小值) / (min.) (典型值) / (typ.) (最大值) / (max.)	V_F V_F V_F	2.7 3.2 3.7	2.7 3.2 3.7	2.7 3.2 3.7	V V V
反向电流 Reverse current	I_R	不设计用于反向运行 not designed for reverse operation			μA
光效 Optical efficiency $I_F = 100\text{ mA}$ (典型值) / (typ.)	η_{opt}	37 %	34 lm/W	128 lm/W	% lm/W
结点-焊点热阻 Thermal resistance (典型值) / (typ.) (最大值) / (max.)	$R_{\text{th JS}}$ $R_{\text{th JS}}$	6.5 11**	6.5 11**	6.5 11**	K/W K/W

* 第 5 页的单个组

Individual groups on page 5

** R_{th} (最大值) 取自统计值 $R_{\text{th}}(\text{max})$ is based on statistic values

波长组 (主波长) 第 20 页 3)

Wavelength Groups (Dominant Wavelength)^{3) page 20}

组 Group	深蓝色 deep blue		蓝色 blue		真绿色 true green		单位 Unit
	最小值 min.	最大值 max.	最小值 min.	最大值 max.	最小值 min.	最大值 max.	
2			459	464			nm
3	449	453	464	468	519	525	nm
4	453	457	468	472	525	531	nm
5	457	461	472	476	531	537	nm
6					537	543	nm

亮度组 (深蓝色)

Brightness Groups (deep blue)

亮度组 Brightness Group	辐射功率 ^{第 20 页 1)} Radiant Power ^{1) page 20} Φ_E (mW)	
3T	355 ...	400
4T	400 ...	450
1U	450 ...	500
2U	500 ...	560
3U	560 ...	630

注释: 系列类型的标准装运格式包括由 5 个单个亮度组组成的产品族亮度组。单个亮度组不接受订购。

Note: The standard shipping format for serial types includes a family group of 5 individual brightness groups. Individual brightness groups cannot be ordered.

亮度组 (蓝色、真绿色)

Brightness Groups (blue, true green)

亮度组 Brightness Group	光通量 ^{第 20 页 1)} Luminous Flux ^{1) page 20} Φ_v (lm)	发光强度 ^{第 20 页 2)} Luminous Intensity ^{2) page 20} I_v (mcd)
GY	21000 ... 24000	7500 (典型值) / (typ.)
GZ	24000 ... 28000	8600 (典型值) / (typ.)
HX	28000 ... 33000	10200 (典型值) / (typ.)
HY	33000 ... 39000	12000 (典型值) / (typ.)
HZ	39000 ... 45000	14000 (典型值) / (typ.)
JX	45000 ... 52000	16200 (典型值) / (typ.)
JY	52000 ... 61000	18300 (典型值) / (typ.)
JZ	61000 ... 71000	22000 (典型值) / (typ.)
KX	71000 ... 82000	25200 (典型值) / (typ.)
KY	82000 ... 97000	29800 (典型值) / (typ.)

注释: 系列类型的标准装运格式包括由 4 个单个亮度组组成的产品族亮度组。单个亮度组不接受订购。

Note: The standard shipping format for serial types includes a family group of 4 individual brightness groups. Individual brightness groups cannot be ordered.

标签上的组名

Group Name on Label

示例: GY-4

Example: GY-4

亮度组 Brightness Group	波长 Wavelength
GY	4

注释: 每个包装单元/卷带均仅包含一个亮度组。

Note: No packing unit / tape ever contain more than one group for each selection.

相对辐射光谱 第 20 页 2)

Relative Spectral Emission²⁾ page 20

$V(\lambda)$ = 标准视觉曲线 / Standard eye response curve

$\Phi_{rel} = f(\lambda); T_A = 25\text{ }^\circ\text{C}; I_F = 350\text{ mA}$

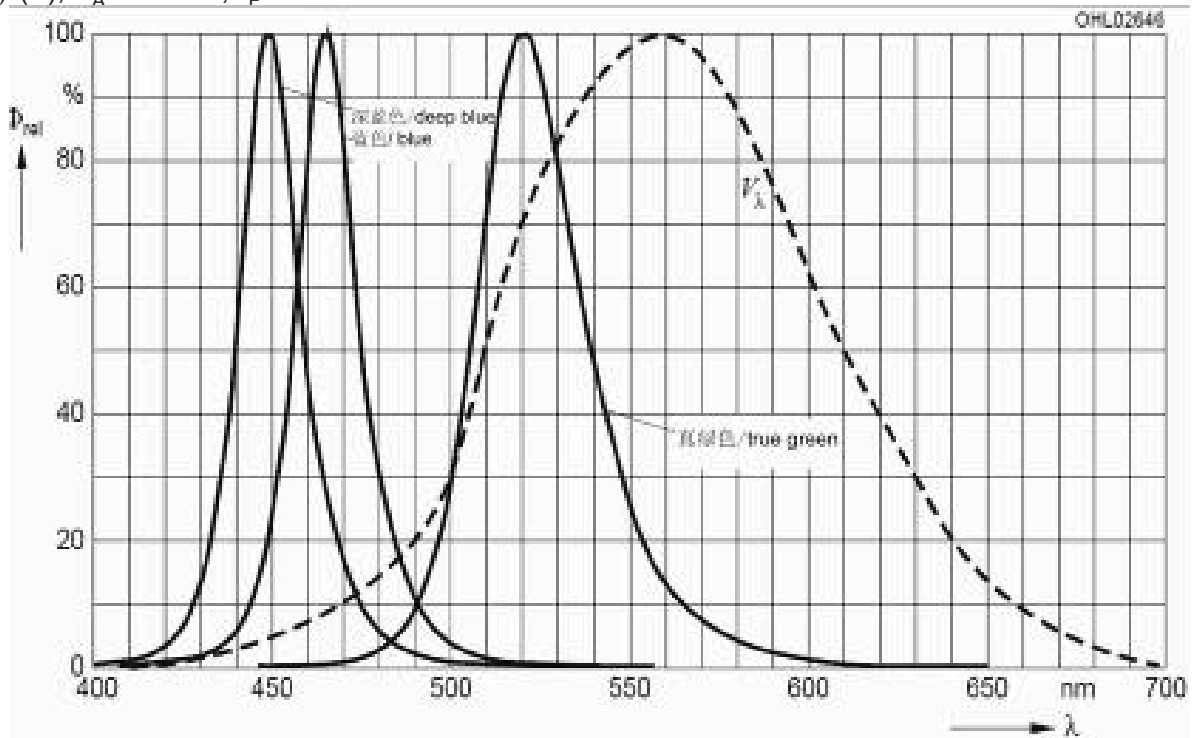

配光曲线 第 20 页 2)

Radiation Characteristic²⁾ page 20

$I_{rel} = f(\varphi); T_A = 25\text{ }^\circ\text{C}$

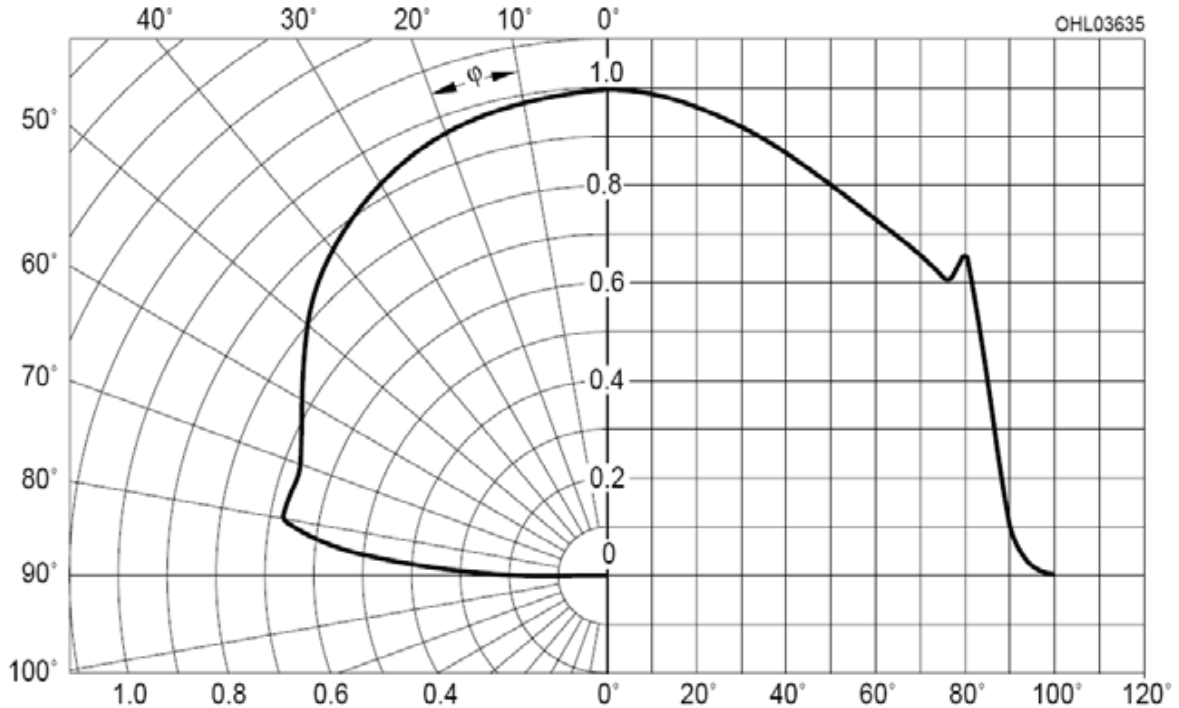

正向电流 第 20 页 2)

Forward Current^{2) page 20}

$I_F = f(V_F); T_A = 25\text{ }^\circ\text{C};$ 蓝色、深蓝色

$I_F = f(V_F); T_A = 25\text{ }^\circ\text{C};$ blue, deep blue

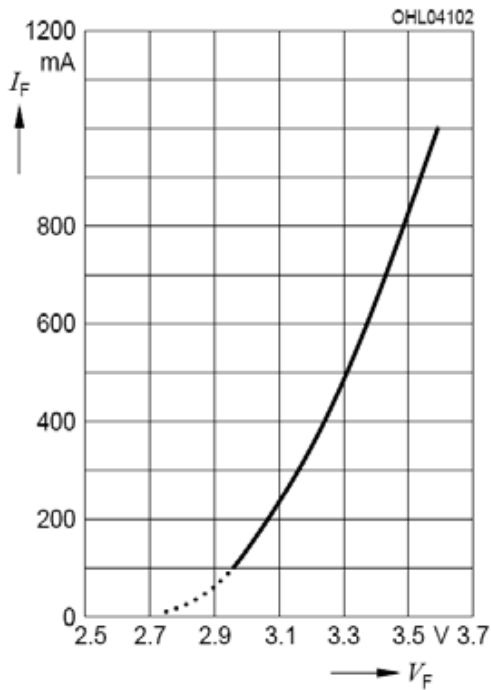

正向电流 第 20 页 2)

Forward Current^{2) page 20}

$I_F = f(V_F); T_A = 25\text{ }^\circ\text{C};$ 真绿色

$I_F = f(V_F); T_A = 25\text{ }^\circ\text{C};$ true green

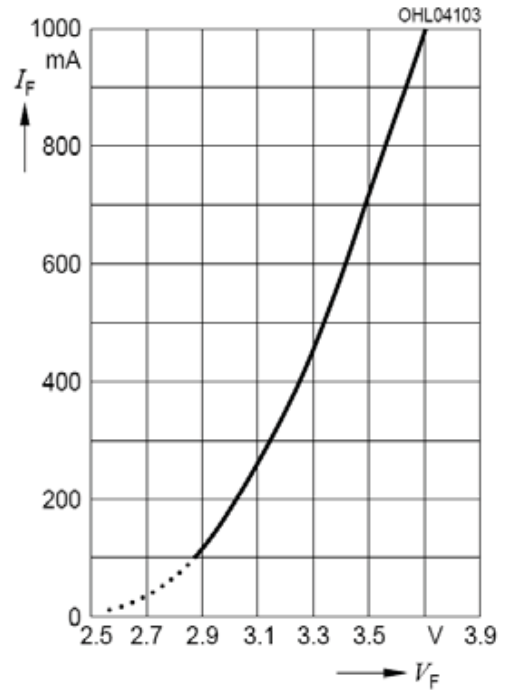

相对光通量 第 20 页 2)、5)

Relative Luminous Flux^{2) 5) page 20}

$\Phi_V/\Phi_V(350\text{ mA}) = f(I_F); T_A = 25\text{ }^\circ\text{C},$ 蓝色

$\Phi_V/\Phi_V(350\text{ mA}) = f(I_F); T_A = 25\text{ }^\circ\text{C},$ blue

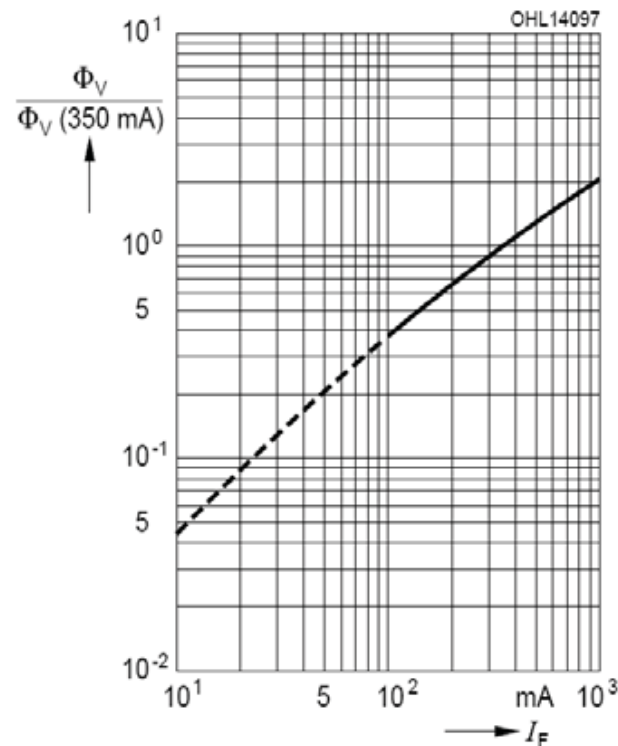

相对辐射功率 第 20 页 2)、5)

Relative Radiant Power^{2) 5) page 20}

$\Phi_E/\Phi_E(350\text{ mA}) = f(I_F); T_A = 25\text{ }^\circ\text{C},$ 深蓝色

$\Phi_E/\Phi_E(350\text{ mA}) = f(I_F); T_A = 25\text{ }^\circ\text{C},$ deep blue

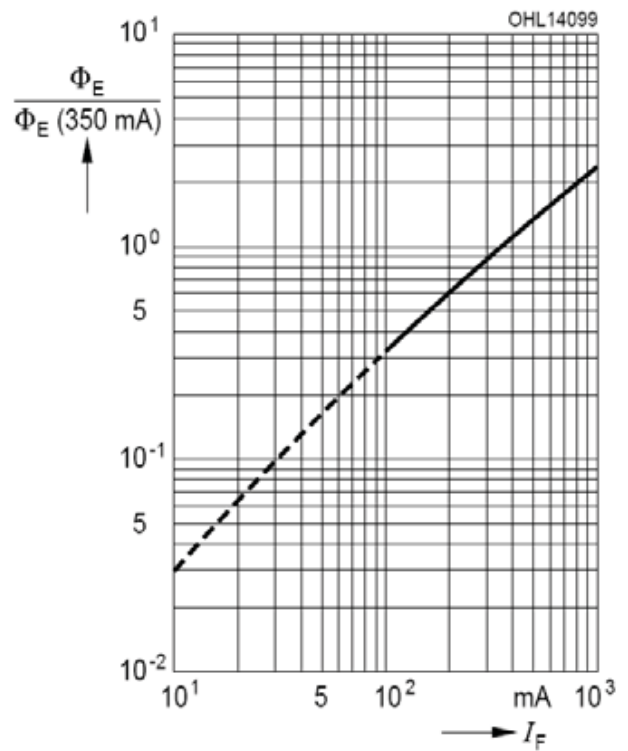

相对光通量 第 20 页 2)、5)

Relative Luminous Flux²⁾ page 20

$\Phi_V / \Phi_V(350 \text{ mA}) = f(I_F); T_A = 25 \text{ }^\circ\text{C}$, 真绿色

$\Phi_V / \Phi_V(350 \text{ mA}) = f(I_F); T_A = 25 \text{ }^\circ\text{C}$, true green

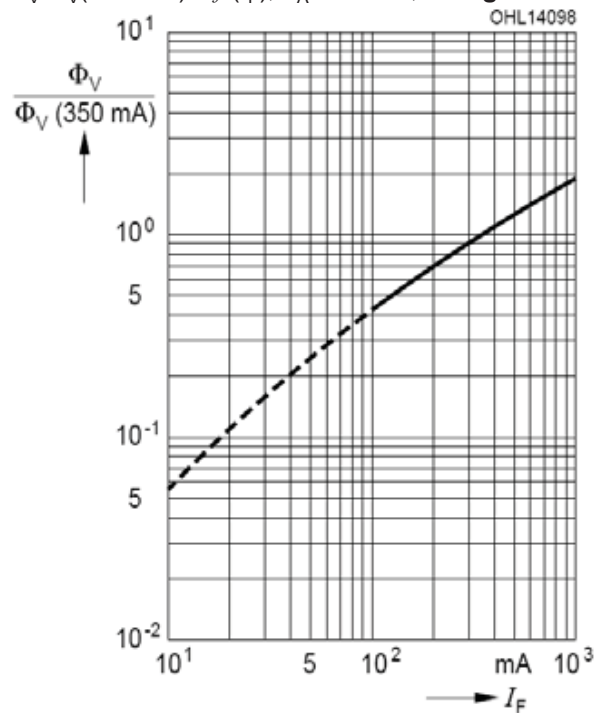

主波长 第 20 页 2)

Dominant Wavelength²⁾ page 20

$\Delta\lambda_{\text{dom}} = f(I_F); T_A = 25 \text{ }^\circ\text{C}$, 蓝色、深蓝色

$\Delta\lambda_{\text{dom}} = f(I_F); T_A = 25 \text{ }^\circ\text{C}$, blue, deep blue

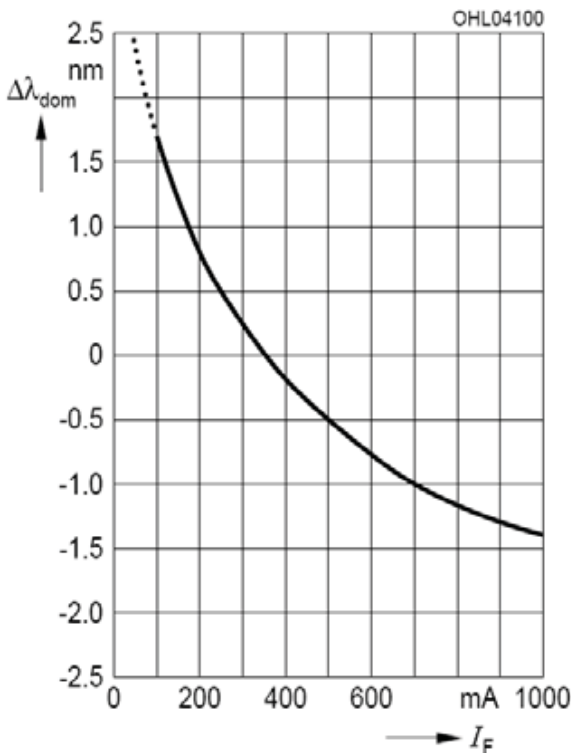

主波长 第 20 页 2)

Dominant Wavelength²⁾ page 20

$\Delta\lambda_{\text{dom}} = f(I_F); T_A = 25 \text{ }^\circ\text{C}$, 真绿色

$\Delta\lambda_{\text{dom}} = f(I_F); T_A = 25 \text{ }^\circ\text{C}$, true green

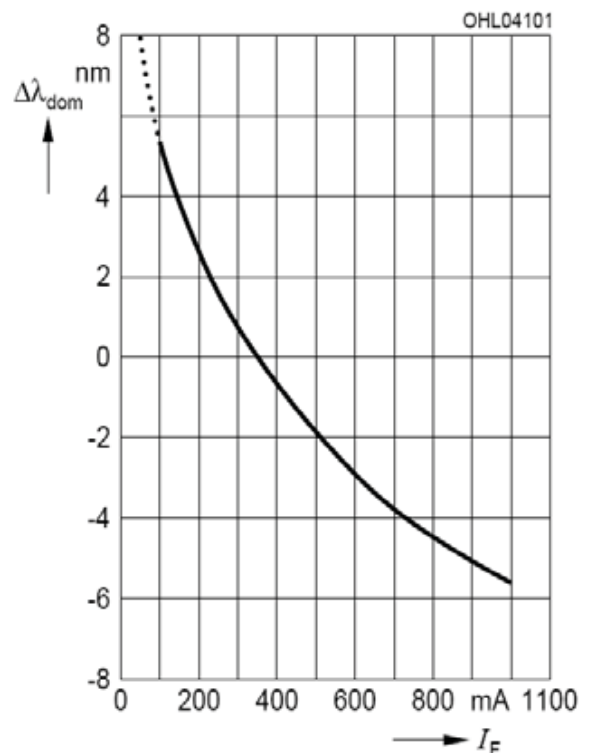

相对正向电压 第 20 页 2)

Relative Forward Voltage^{2) page 20}

$$\Delta V_F = V_F - V_F(25\text{ }^\circ\text{C}) = f(T_j); I_F = 350\text{ mA}$$

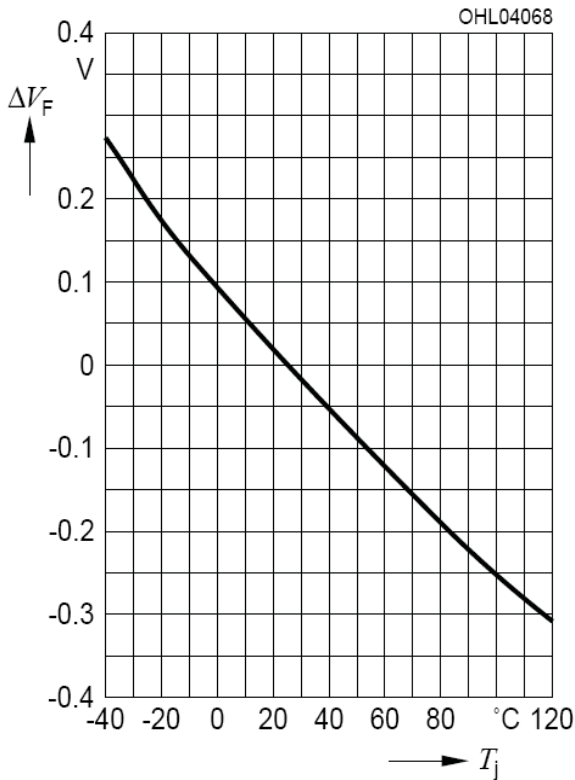

相对光通量 第 20 页 2)

Relative Luminous Flux^{2) page 20}

$$\Phi_V / \Phi_V(25\text{ }^\circ\text{C}) = f(T_j); I_F = 350\text{ mA}$$

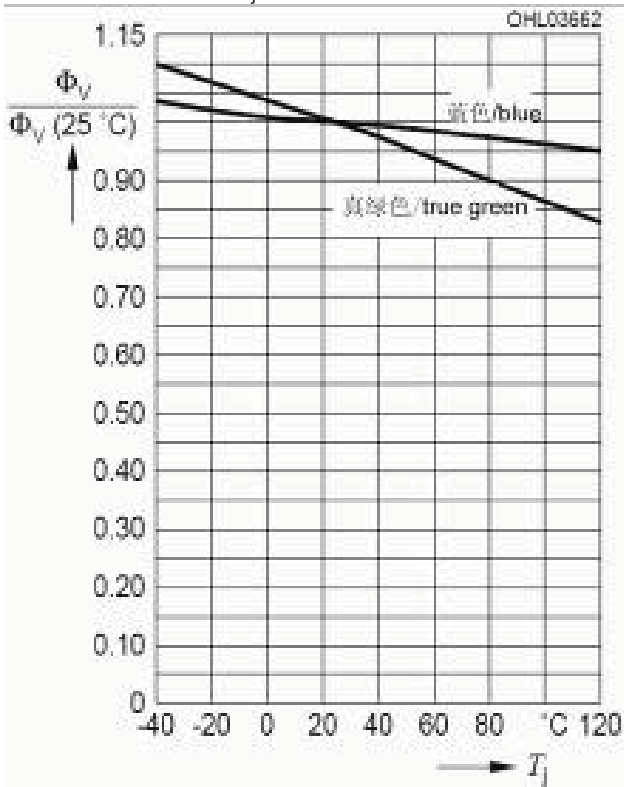

相对辐射功率 第 20 页 2)

Relative Radiant Power^{2) page 20}

$$\Phi_E / \Phi_E(25\text{ }^\circ\text{C}) = f(T_j); I_F = 350\text{ mA}$$

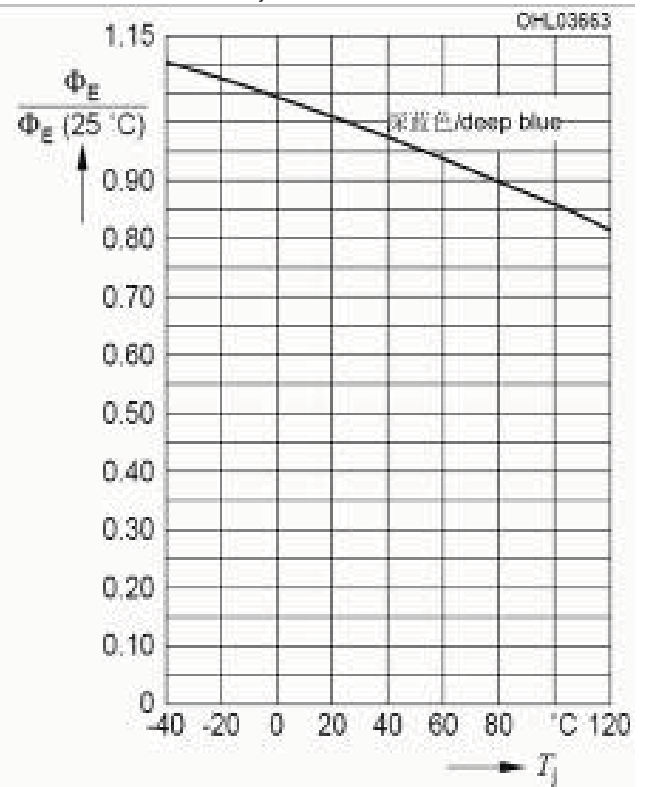

主波长 第 20 页 2)

Dominant Wavelength²⁾ page 20

$\lambda_{\text{dom}} = f(T_j); I_F = 350 \text{ mA}$ (深蓝色、蓝色)

$\lambda_{\text{dom}} = f(T_j); I_F = 350 \text{ mA}$ (deep blue, blue)

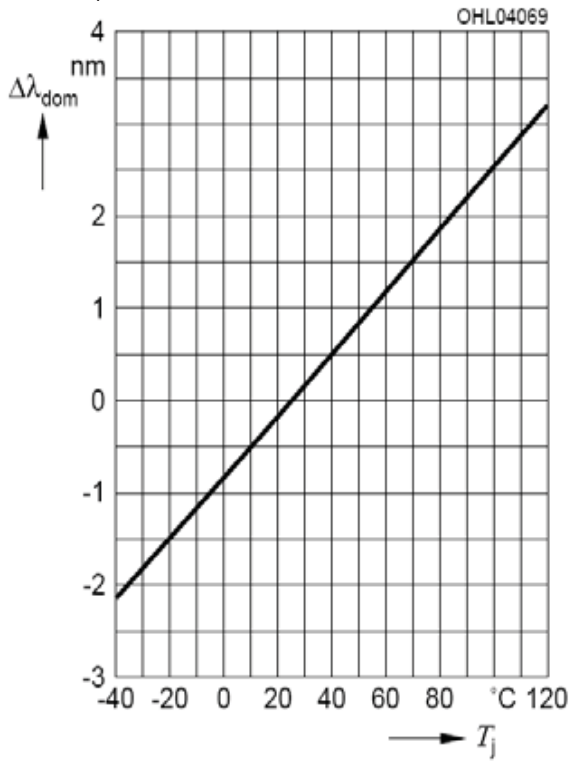

主波长 第 20 页 2)

Dominant Wavelength²⁾ page 20

$\lambda_{\text{dom}} = f(T_j); I_F = 350 \text{ mA}$ (真绿色)

$\lambda_{\text{dom}} = f(T_j); I_F = 350 \text{ mA}$ (true green)

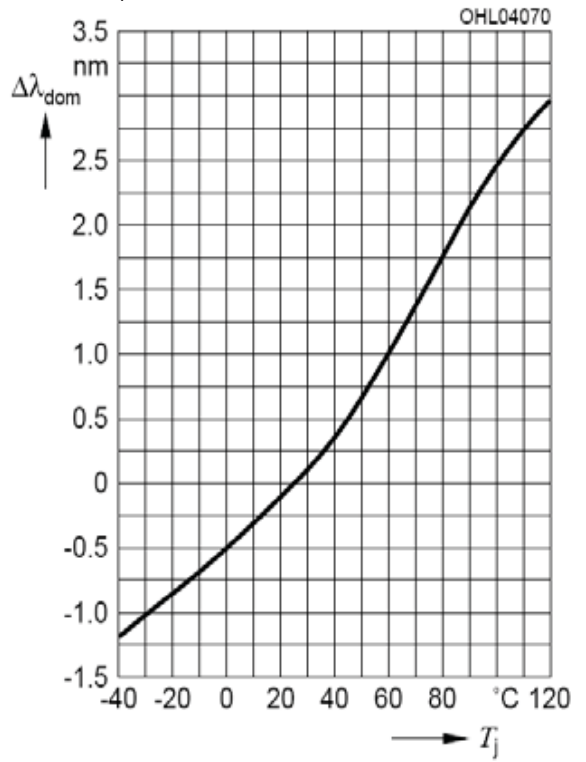

最大容许正向电流
Max. Permissible Forward Current
 $I_F = f(T_S)$

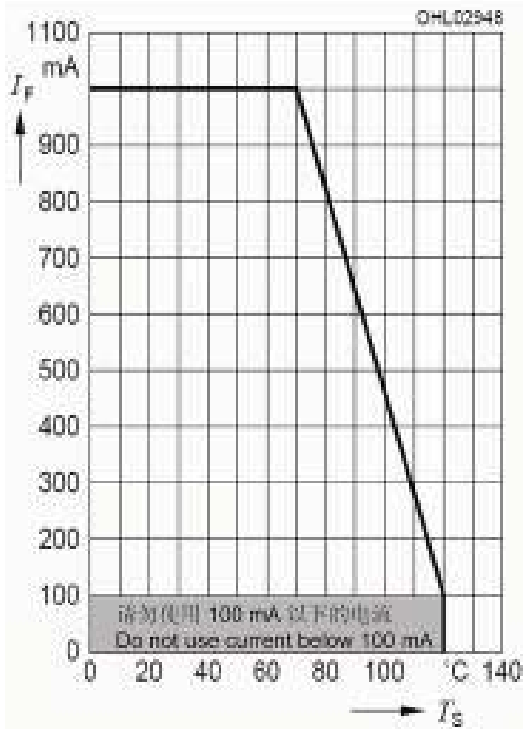

容许脉冲调制能力 $I_F = f(t_p)$
Permissible Pulse Handling Capability
 占空比 $D =$ 参数, $T_S = 25^\circ\text{C}$
 Duty cycle $D =$ parameter, $T_S = 25^\circ\text{C}$

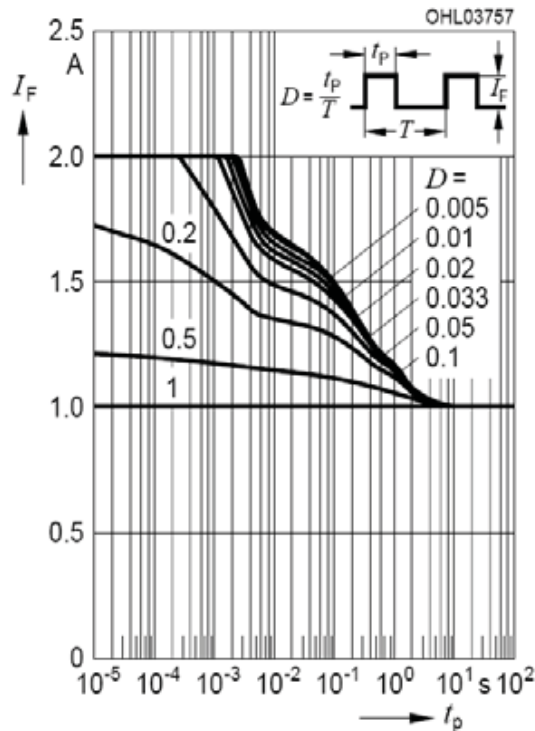

中等亮度组的典型平均使用寿命 ^{第 20 页 2)}
Exemplary median Lifetime ^{2) page 20}
 for median Brightness Group

条件 Conditions	平均使用寿命 median Lifetime	单位 Unit
$I_F = 500 \text{ mA}$ $T_S = 25^\circ\text{C}$	待定 t.b.d.	工作小时 operating hours
$I_F = 700 \text{ mA}$ $T_S = 85^\circ\text{C}$	待定 t.b.d.	工作小时 operating hours

*LED 芯片显示出卓越的性能，但是当温度达到最高值时出现轻微的封装变色。平均使用寿命取决于具体应用。
 *The emitter die exhibits excellent performance but slight package discoloration occurs at highest temperatures. The median lifetime depends on the application

容许脉冲调制能力 $I_F = f(t_p)$
Permissible Pulse Handling Capability
 占空比 $D =$ 参数, $T_S = 85^\circ\text{C}$
 Duty cycle $D =$ parameter, $T_S = 85^\circ\text{C}$

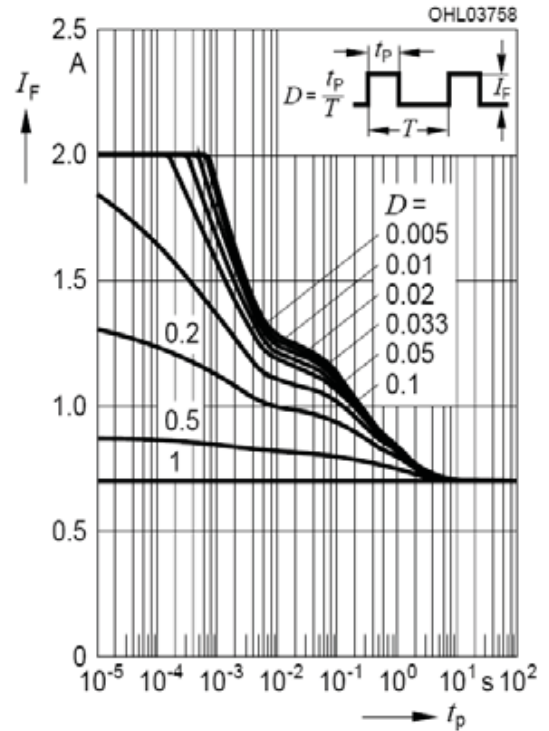

封装略图 第 20 页 6)

Package Outlines 6) page 20

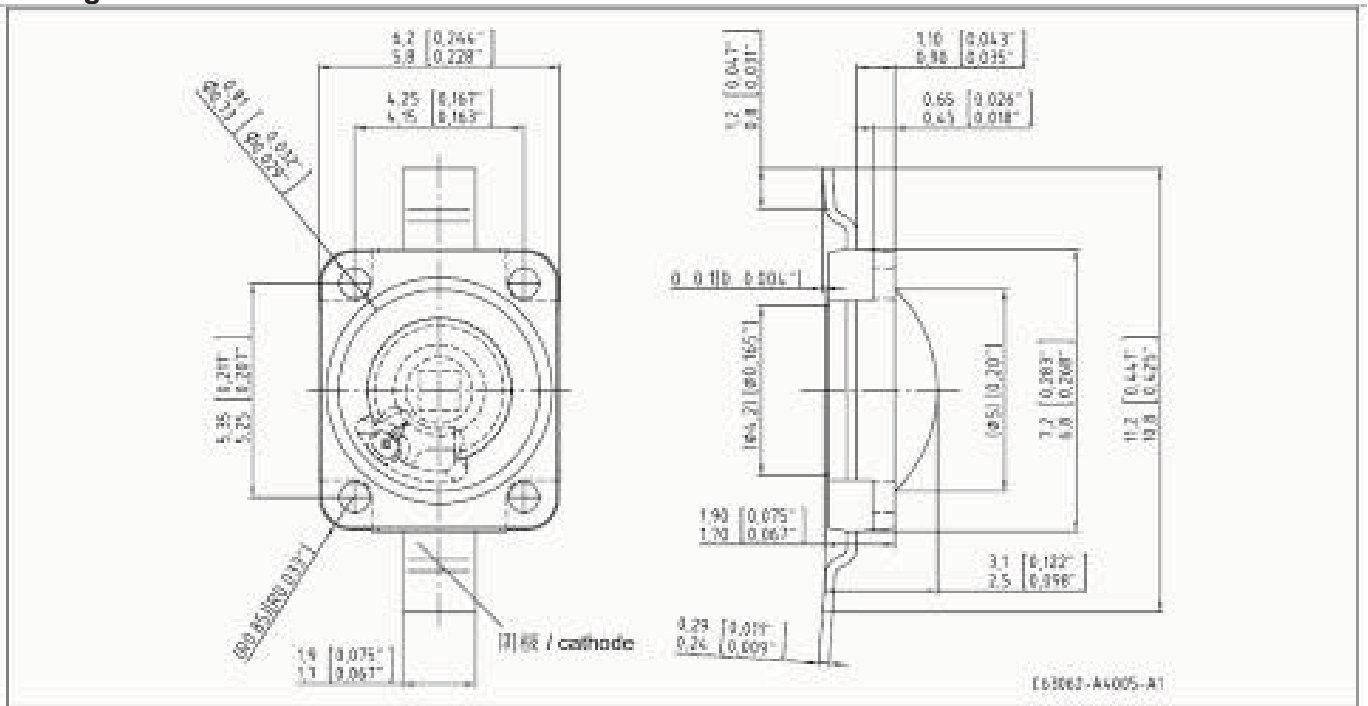

阴极标记:

Cathode mark:

参考重量 / Approx. weight:

标记

mark

0.2 g

卷带封装方式/极性和方向 第 20 页 6)

Method of Taping / Polarity and Orientation 6) page 20

包装单元 200/卷, 直径为 180 mm

Packing unit 200/reel, \varnothing 180 mm

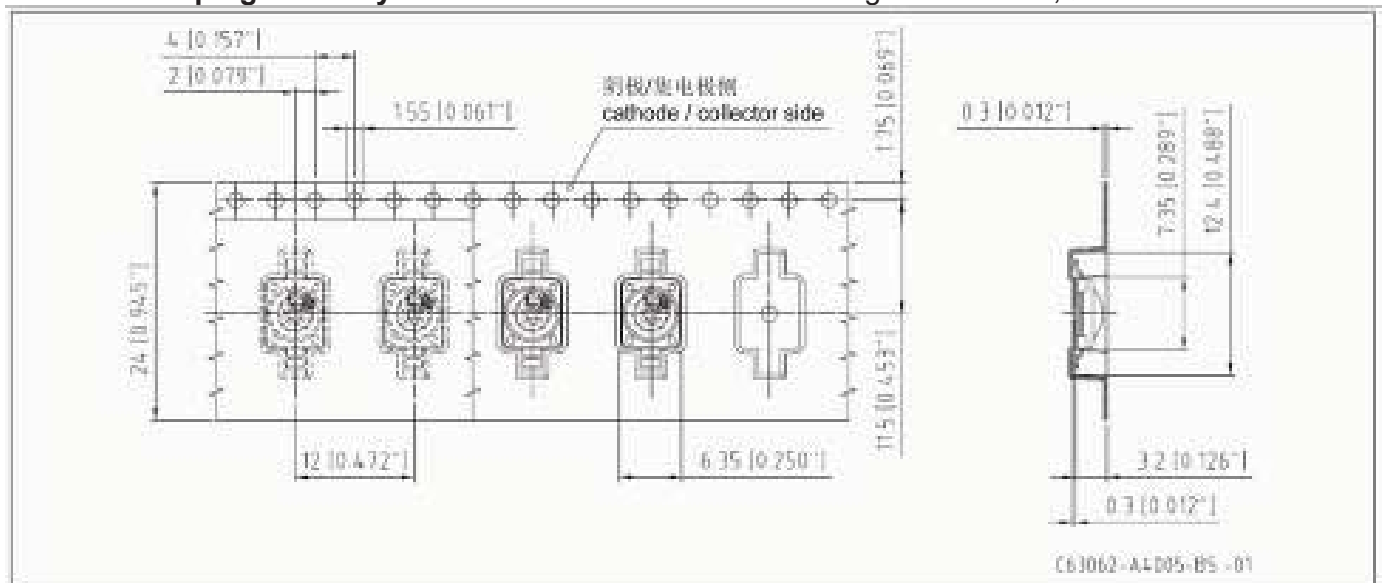

焊接条件

Soldering Conditions

无铅焊接的 IR 回流焊接温度曲线简图

IR Reflow Soldering Profile for lead free soldering

预处理符合 JEDEC 4 级标准

Preconditioning acc. to JEDEC Level 4

(符合 J-STD-020D 标准)

(acc. to J-STD-020D)

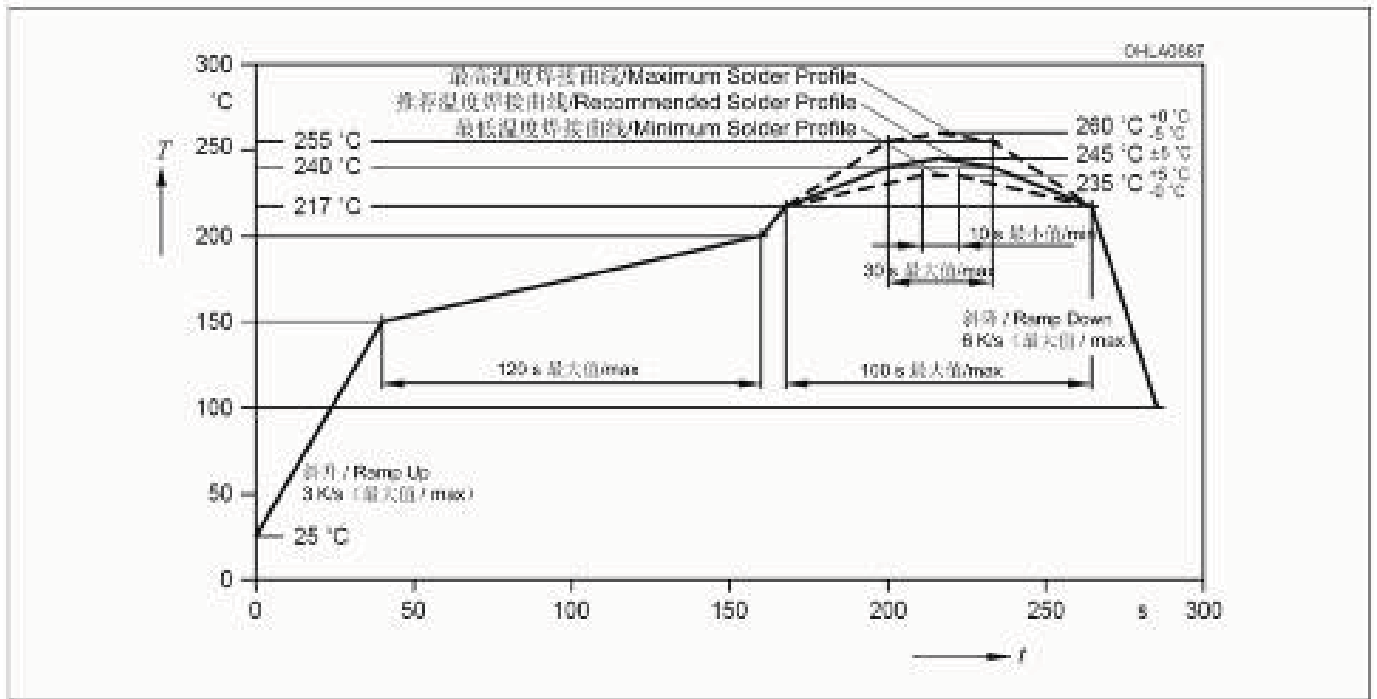

注释：此封装不适宜超声波清洗

Note: Package not suitable for ultra sonic cleaning

条形码——产品标签 (BPL)
Barcode-Product-Label (BPL)

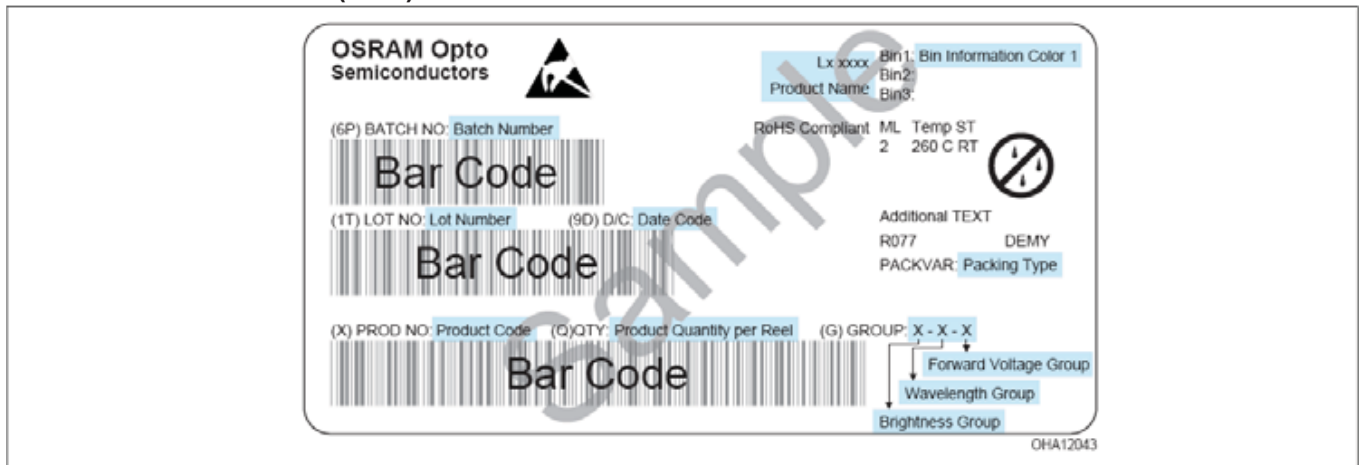

卷带和卷盘
Tape and Reel

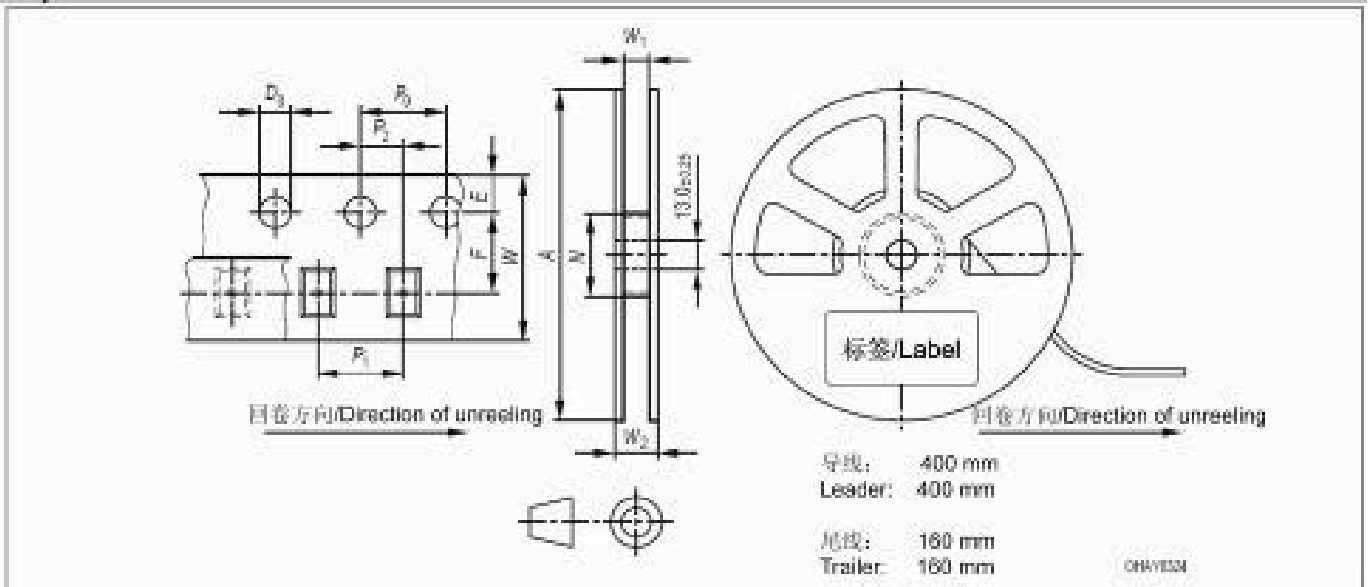

卷带尺寸 (单位: mm (英寸)) / Tape dimensions in mm (inch)

W	P_0	P_1	P_2	D_0	E	F
$24^{+0.3}_{-0.1}$	4 ± 0.1 (0.157 ± 0.004)	8 ± 0.1 (0.315 ± 0.004)	2 ± 0.1 (0.079 ± 0.004)	1.5 ± 0.1 (0.059 ± 0.004)	1.75 ± 0.1 (0.069 ± 0.004)	11.5 ± 0.1 (0.453 ± 0.004)

卷盘尺寸 (单位: mm (英寸)) / Reel dimensions in mm (inch)

A	W	N_{min}	W_1	$W_2 \max$
180 (7)	24 (0.945)	60 (2.362)	$24.4 + 2$ ($0.961 + 0.079$)	30.4 (1.197)

干式充填工艺和材料
Dry Packing Process and Materials

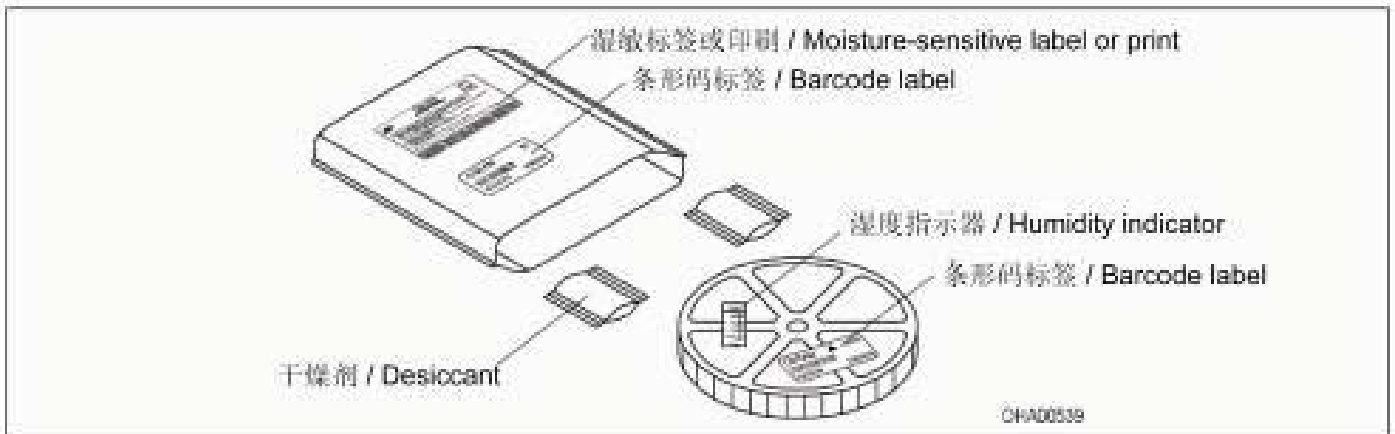

注释: 湿敏产品包装在装有干燥剂和湿度卡的干燥袋子中。
关于干式充填的详细信息, 请参阅网站资料和简明版产品目录中“干式充填”标题下的“卷带和卷盘”章节。
您还可以找到 JEDEC 等规范性参考。

Note: Moisture-sensitive product is packed in a dry bag containing desiccant and a humidity card.
Regarding dry pack you will find further information in the internet and in the Short Form Catalog in chapter “Tape and Reel” under the topic “Dry Pack”. Here you will also find the normative references like JEDEC.

运输包装和材料
Transportation Packing and Materials

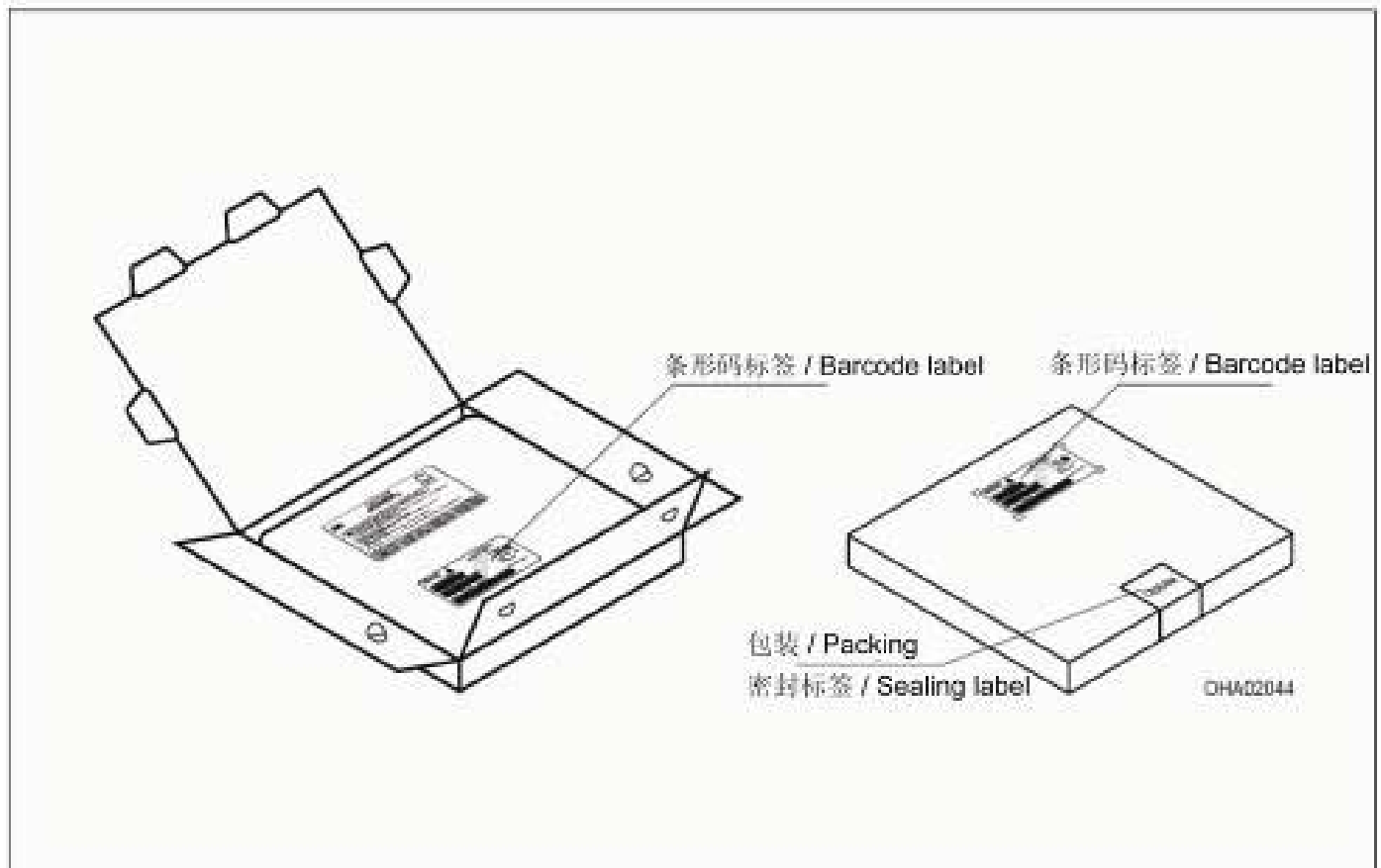

修订记录 / Revision History: 2009-10-19

先前版本 / Previous Version: 2009-10-16

页码 Page	更改内容（自上次修订后的主要更改） Subjects (major changes since last revision)	更改日期 Date of change
全部 / all	创建规格书 / datasheet created	2008-11-06
2, 3	更正订购代码 / ordering code corrected	2009-03-16
5	更正热阻 R_{thJS} （典型值） / Thermal resistance R_{thJS} (typ.) corrected	2009-04-22
2	变更订购代码（深蓝色） / Ordering code (deep blue) changed	2009-04-24
4	OS-IN-2009-020（降低正向电压最大值） OS-IN-2009-020 (Forward voltage max reduced)	2009-06-16
14	更新封装略图和卷带封装方式 / 极性和方向 Package Outlines and Method of Taping / Polarity and Orientation	2009-06-19
2, 3, 7	更改订购代码（深蓝色）的亮度范围 ordering code (blue): brightness range changed	2009-10-16
1, 14	更正包装单元 / Packing unit corrected	2009-10-19
1	更新典型光通量 / typical Luminous Flux updated	2009-10-19
1, 5	更新光效 / optical efficiency updated	2009-10-19

请注意！

元件类型的描述性信息不应被视为对特性的保证。

欧司朗保留交货条件和变更设计的权力。因技术需要，元件可能包含危险物质。如果对类型信息有疑问，请联系我们的销售部门。

如需打印或下载，请到公司网站寻找最新版本。

Attention please!

The information describes the type of component and shall not be considered as assured characteristics.

Terms of delivery and rights to change design reserved. Due to technical requirements components may contain dangerous substances. For information on the types in question please contact our Sales Organization.

If printed or downloaded, please find the latest version in the Internet.

封装

请联系您所熟悉的物资回收公司。我们也可以帮助您联系最近的销售办事处。如果您已对包装材料进行了分类，我们将根据协议进行回收，所产生的运输费用须由您承担。对于未经分类即退回本公司或我们没有责任接受的包装材料，我们将开具发票由您支付因此产生的一切费用。

Packing

Please use the recycling operators known to you. We can also help you – get in touch with your nearest sales office. By agreement we will take packing material back, if it is sorted. You must bear the costs of transport. For packing material that is returned to us unsorted or which we are not obliged to accept, we shall have to invoice you for any costs incurred.

生命支持装置或系统所采用的元件必须获取该目的明确授权！ 仅当获得欧司朗公司的明确书面许可时，方可将关键元件第 20 页 7) 用于生命支持装置或系统第 20 页 8)。

Components used in life-support devices or systems must be expressly authorized for such purpose! Critical components^{7) page 20} may only be used in life-support devices or systems^{8) page 20} with the express written approval of OSRAM OS.

备注:

- 1) 亮度组的测试电流脉冲时长为 25 ms，容差为 $\pm 11\%$ 。
- 2) 由于 LED 制造工艺的条件特殊，典型或计算得出的技术参数数据仅能反映统计数据，而不等同于各产品的实际参数，它们可能与典型或计算得出的典型特征线数据不同。如果需要（如由于技术改进），这些典型数据将有所变更，恕不另行通知。
- 3) 波长的测试电流脉冲时长为 25 ms，容差为 ± 1 nm。
- 4) 正向电压的测试电流脉冲时长为 1 ms，容差为 ± 0.1 V。
- 5) 在虚线范围内，单个包装单元内的不同 LED 之间的明暗差别会更大。
- 6) 尺寸单位指定为：mm（英寸）。
- 7) 关键元件指用在生命支持装置或系统中，一旦发生故障即会引起装置或系统故障或影响其安全性或有效性的元件。
- 8) 生命支持装置或系统拟用于 (a) 植入人体或 (b) 支持和/或维持人的生命。如果发生故障，即会威胁使用者的健康和生命。

Remarks:

- 1) Brightness groups are tested at a current pulse duration of 25 ms and a tolerance of $\pm 11\%$.
- 2) Due to the special conditions of the manufacturing processes of LED, the typical data or calculated correlations of technical parameters can only reflect statistical figures. These do not necessarily correspond to the actual parameters of each single product, which could differ from the typical data and calculated correlations or the typical characteristic line. If requested, e.g. because of technical improvements, these typ. data will be changed without any further notice.
- 3) Wavelengths are tested at a current pulse duration of 25 ms and a tolerance of ± 1 nm.
- 4) Forward voltages are tested at a current pulse duration of 1 ms and a tolerance of ± 0.1 V.
- 5) In the range where the line of the graph is broken, you must expect higher brightness differences between single LEDs within one packing unit.
- 6) Dimensions are specified as follows: mm (inch).
- 7) A critical component is a component used in a life-support device or system whose failure can reasonably be expected to cause the failure of that life-support device or system, or to affect its safety or the effectiveness of that device or system.
- 8) Life support devices or systems are intended (a) to be implanted in the human body, or (b) to support and/or maintain and sustain human life. If they fail, it is reasonable to assume that the health and the life of the user may be endangered.

欧司朗光电半导体有限公司出版
 德国雷根斯堡莱布尼茨大街 4 号 D-93055
www.osram-os.com
 © 保留所有权利

Published by
OSRAM Opto Semiconductors GmbH
 Leibnizstrasse 4, D-93055 Regensburg
www.osram-os.com
 © All Rights Reserved.

EU RoHS and China RoHS compliant product



此产品符合欧盟 RoHS 指令的要求；
 按照中国的相关法规和标准，不含有毒有害物质或元素。