

# Golden DRAGON Plus — 带芯片级转换 (CLC) 的 LED

无铅设计, 符合 RoHS 标准

## Golden DRAGON Plus with Chip Level Conversion (CLC)

Lead (Pb) Free Product - RoHS Compliant

### LUW W5AM



#### 初步数据 / Preliminary Data

##### 特点

- **封装:** 白色 SMD 封装, 无色透明硅树脂, 透明硅树脂透镜, 芯片级转换
- **典型光通量:** 113 lm (工作电流为 350 mA 时), 最大 267 lm (工作电流为 1 A 时)
- **置特点:** 小尺寸高效光源
- **颜色坐标:** (白色)  $x = 0,31, y = 0,32$  (符合 CIE 1931 色度坐标图)
- **典型色温:** 6500 K
- **视角:** 170°
- **技术:** ThinGaN
- **光效:** 128 lm/W (工作电流为 100 mA 时)
- **分组参数:** 光通量、颜色坐标
- **组装方式:** 适用于所有表面封装方式
- **焊接方式:** 回流焊接
- **预处理:** 符合 JEDEC 4 级标准
- **卷带封装:** 24 mm 卷带, 200/卷, 直径为 180 mm
- **ESD 耐压:**  $\geq 2$  kV (符合 JESD22-A114-D 标准)

##### 应用

- 闪光灯
- 背光照明 (广告灯光、普通照明)
- 阅读灯
- 取代微型白炽灯
- 商业和住宅建筑室内外照明
- 要求高亮度的显示器背光源
- 装饰和娱乐照明
- 导向用信号和符号灯
- 标志灯 (如台阶灯、出口通道灯等)
- 街道照明
- 隧道照明
- 天花灯

##### Features

- **Package:** white SMD package, colorless clear silicone resin, clear silicone lens, chip level conversion
- **Typical Luminous Flux:** 113 lm at 350 mA up to 267 lm at 1 A
- **Feature of the device:** high efficient lightsource at low space
- **Color coordinates:**  $x = 0.31, y = 0.32$  acc. to CIE 1931 (white)
- **Typ. color temperature:** 6500 K
- **Viewing angle:** 170°
- **Technology:** ThinGaN
- **Optical efficiency:** 128 lm/W at 100 mA
- **Grouping parameter:** luminous flux, color coordinates
- **Assembly methods:** suitable for all SMT assembly methods
- **Soldering methods:** reflow soldering
- **Preconditioning:** acc. to JEDEC Level 4
- **Taping:** 24 mm tape with 200/reel,  $\varnothing 180$  mm
- **ESD-withstand voltage:** up to 2 kV acc. to JESD22-A114-D

##### Applications

- Flashlight
- Backlighting (illuminated advertising, general lighting)
- Reading lamps
- Substitution of micro incandescent lamps
- Indoor and outdoor commercial and residential architectural lighting
- Display backlight where high brightness is required
- Decorative and entertainment lighting
- Signal and symbol luminaire for orientation
- Marker lights (e.g. steps, exit ways, etc.)
- Street lighting
- Tunnel lighting
- Ceiling light

订购信息

Ordering Information

类型 Type	发光颜色 Color of Emission	光通量 <sup>第 20 页 1)</sup> Luminous Flux <sup>1) page 20</sup> $I_F = 350 \text{ mA}$ $\Phi_V \text{ (mlm)}$	发光强度 <sup>第 20 页 2)</sup> Luminous Intensity <sup>2) page 20</sup> $I_F = 350 \text{ mA}$ $I_V \text{ (mcd)}$	订购代码 Ordering Code
LUW W5AM-KYLX-6P7Q	白色 / white	82.000 ... 130.000	26.500 (典型值) / (typ.)	Q65110A7564
LUW W5AM-KZLY-6P7R	白色 / white	97.000 ... 150.000	30.900 (典型值) / (typ.)	Q65110A8397
LUW W5AM-LXLY-6P7R	白色 / white	112.000 ... 150.000	32.800 (典型值) / (typ.)	Q65110A8399

订购信息

Ordering Information

类型 Type	色温 Color temperature	光通量 <sup>第 20 页 1)</sup> Luminous Flux <sup>1) page 20</sup> $I_F = 350 \text{ mA}$ $\Phi_V \text{ (mlm)}$	发光强度 <sup>第 20 页 2)</sup> Luminous Intensity <sup>2) page 20</sup> $I_F = 350 \text{ mA}$ $I_V \text{ (mcd)}$	订购代码 Ordering Code
LUW W5AM-KYLX-4C8E	6500 K	82.000 ... 130.000	26.500 (典型值) / (typ.)	Q65110A9531
LUW W5AM-KYLX-4E8G	5700 K	82.000 ... 130.000	26.500 (典型值) / (typ.)	Q65110A9533

注释: 上述类型编号代表仅包含几个亮度组的订购组 (详细说明请参见第 8 页)。每个卷盘上仅装运一个亮度组 (一个卷盘上不会混装两个亮度组)。例如, LUW W5AM-KZLY-6P7R 表示任何一个卷盘仅可装运一个亮度组: KZ、LX 或 LY。  
为了确保可用性, 单个亮度组将不接受订购。

类似地, 对于需要测量和分选色度坐标组的颜色, 每个卷盘上将仅装运一个色度坐标组。例如, LCW LUW W5AM-KZLY-6P7R 表示仅可装运从 6P 到 7R 范围内的一个色度坐标组。  
为了确保可用性, 单个色度坐标组将不接受订购 (详细说明请参见第 5 页)。

Note: The above Type Numbers represent the order groups which include only a few brightness groups (see page 8 for explanation). Only one group will be shipped on each reel (there will be no mixing of two groups on each reel). E.g. LUW W5AM-KZLY-6P7R means that only one group KZ, LX or LY will be shippable for any one reel. In order to ensure availability, single brightness groups will not be orderable.

In a similar manner for colors where chromaticity coordinate groups are measured and binned, single chromaticity coordinate groups will be shipped on any one reel. E.g. LUW W5AM-KZLY-6P7R means that only 1 chromaticity coordinate group -6P to 7R will be shippable on each reel (see page 5 for explanation). In order to ensure availability, single chromaticity coordinate groups will not be orderable.

最大额定值  
Maximum Ratings

参数 Parameter	符号 Symbol	值 Value	单位 Unit
工作温度范围 Operating temperature range	$T_{op}$	- 40 ... + 110	°C
储存温度范围 Storage temperature range	$T_{stg}$	- 40 ... + 110	°C
结点温度 Junction temperature	$T_j$	125	°C
正向电流(环境温度25°C) (最小值) / (min.) Forward current (环境温度25°C) (最大值) / (max.) ( $T_A = 25^\circ\text{C}$ )	$I_F$ $I_F$	100 1000	mA mA
脉冲电流 Surge current $t \leq 10 \mu\text{s}$ , $D = 0.005$ , $T_A = 25^\circ\text{C}$	$I_{FM}$	2000	mA
反向电压 Reverse voltage ( $T_A = 25^\circ\text{C}$ )	$V_R$	不设计用于反向运行 not designed for reverse operation	V
功耗 Power consumption ( $T_A = 25^\circ\text{C}$ )	$P_{tot}$	3.8	W

特性

Characteristics

( $T_A = 25^\circ\text{C}$ )

参数 Parameter	符号 Symbol	值 Value	单位 Unit
CIE1931色度坐标 x <sup>第 20 页 5)</sup> (典型值) / (typ.) Chromaticity coordinate x acc. to CIE 1931 <sup>5) page 20</sup> $I_F = 350 \text{ mA}$	x	0.31	—
CIE1931色度坐标 y <sup>第 20 页 5)</sup> (典型值) / (typ.) Chromaticity coordinate y acc. to CIE 1931 <sup>5) page 20</sup> $I_F = 350 \text{ mA}$	y	0.32	—
50 % $I_V$ 时的全视角 (典型值) / (typ.) Viewing angle at 50 % $I_V$	2 $\varphi$	170	度 deg.
正向电压 <sup>第 20 页 6)</sup> (最小值) / (min.) Forward voltage <sup>6) page 20</sup> (典型值) / (typ.) $I_F = 350 \text{ mA}$ (最大值) / (max.)	$V_F$ $V_F$ $V_F$	2.7 3.2 3.7	V V V
反向电流 (最大值) / (max.) Reverse current	$I_R$	不设计用于反向运行 not designed for reverse operation	$\mu\text{ A}$
光效 (典型值) / (typ.) Optical efficiency $I_F = 100 \text{ mA}$	$\eta_{\text{opt}}$	128	lm/W
结点-焊点热阻 (典型值) / (typ.) Thermal resistance Junction/soldering point (最大值) / (max.)	$R_{\text{th JS}}$ $R_{\text{th JS}}$	6.5 11*	K/W K/W

\* $R_{\text{th}}$  (最大值) 取自统计值  
 $R_{\text{th}}(\text{max})$  is based on statistic values

色度坐标组 第 20 页 5)

Chromaticity coordinate groups<sup>5)</sup> page 20

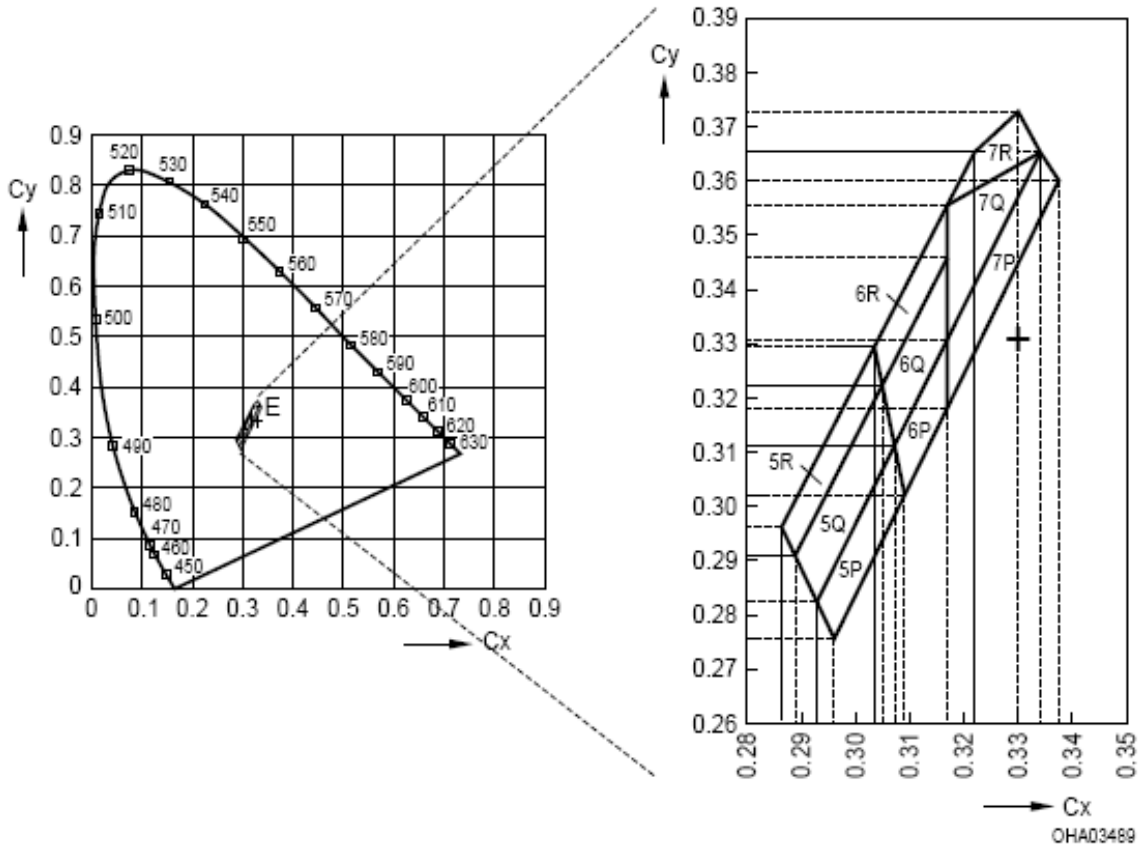

组 Group	Cx	Cy
5P	0.296	0.276
	0.293	0.282
	0.307	0.311
	0.309	0.302
6P	0.309	0.302
	0.307	0.311
	0.317	0.331
	0.317	0.318
7P	0.317	0.318
	0.317	0.331
	0.334	0.365
	0.338	0.360

组 Group	Cx	Cy
5Q	0.293	0.282
	0.289	0.291
	0.305	0.322
	0.307	0.311
	0.307	0.311
6Q	0.307	0.311
	0.305	0.322
	0.317	0.346
	0.317	0.331
7Q	0.317	0.331
	0.317	0.356
	0.334	0.365
	0.317	0.331
	0.317	0.331

组 Group	Cx	Cy
5R	0.289	0.291
	0.287	0.296
	0.304	0.329
	0.305	0.322
6R	0.305	0.322
	0.304	0.329
	0.317	0.356
	0.317	0.346
7R	0.317	0.356
	0.322	0.365
	0.330	0.373
	0.334	0.365
	0.317	0.331

色度坐标组 第 20 页 5)

Chromaticity coordinate groups<sup>5)</sup> page 20

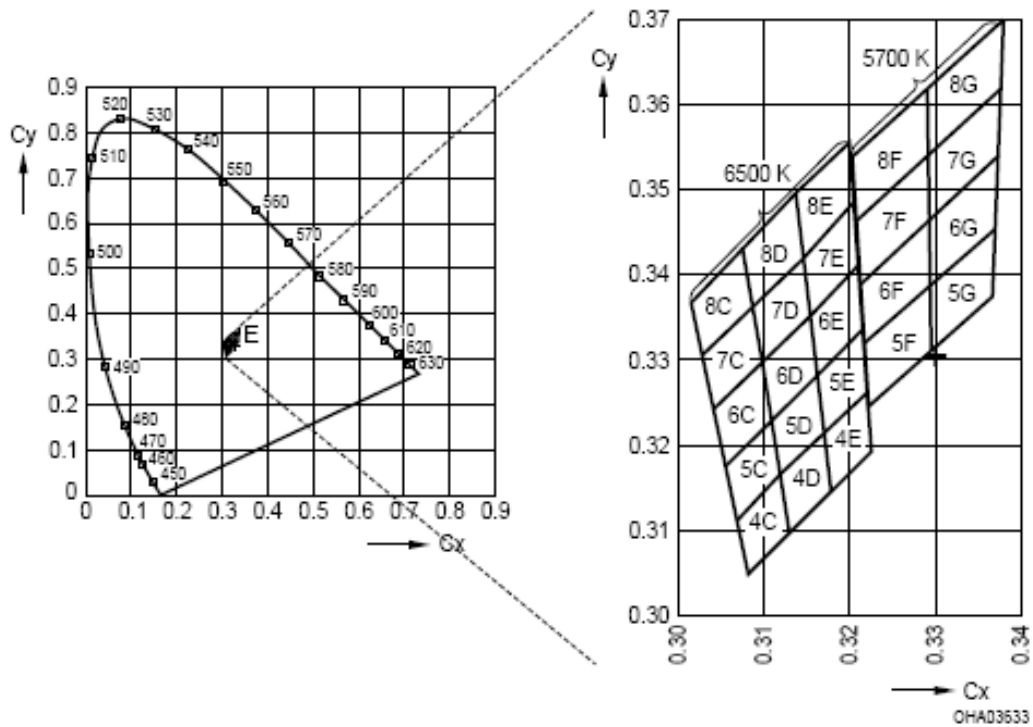

组 Group	Cx	Cy
4C	0.308	0.305
	0.307	0.311
	0.312	0.316
	0.313	0.310
5C	0.307	0.311
	0.306	0.318
	0.311	0.323
	0.312	0.316
6C	0.306	0.318
	0.304	0.324
	0.310	0.330
	0.311	0.323
7C	0.304	0.324
	0.303	0.330
	0.309	0.336
	0.310	0.330
8C	0.303	0.330
	0.302	0.337
	0.308	0.343
	0.309	0.336

组 Group	Cx	Cy
5F	0.322	0.324
	0.322	0.332
	0.329	0.338
	0.329	0.331
6F	0.322	0.332
	0.321	0.339
	0.329	0.346
	0.329	0.338
7F	0.321	0.339
	0.321	0.346
	0.329	0.354
	0.329	0.346
8F	0.321	0.346
	0.320	0.354
	0.329	0.362
	0.329	0.354
5G	0.329	0.331
	0.329	0.338
	0.337	0.345
	0.337	0.337

组 Group	Cx	Cy
4D	0.313	0.310
	0.312	0.316
	0.317	0.321
	0.318	0.314
5D	0.312	0.316
	0.311	0.323
	0.316	0.328
	0.317	0.321
6D	0.311	0.323
	0.310	0.330
	0.315	0.335
	0.316	0.328
7D	0.310	0.330
	0.309	0.336
	0.315	0.342
	0.315	0.335
8D	0.309	0.336
	0.308	0.343
	0.314	0.349
	0.315	0.342
4E	0.318	0.314
	0.317	0.321
	0.322	0.326
	0.323	0.319
5E	0.317	0.321
	0.316	0.328
	0.322	0.333
	0.322	0.326
6E	0.316	0.328
	0.315	0.335
	0.321	0.341
	0.322	0.333
7E	0.315	0.335
	0.315	0.342
	0.321	0.348
	0.321	0.341
8E	0.315	0.342
	0.314	0.349
	0.320	0.355
	0.321	0.348

组 Group	Cx	Cy
6G	0.329	0.338
	0.329	0.346
	0.337	0.353
	0.337	0.345
7G	0.329	0.346
	0.329	0.354
	0.338	0.362
	0.337	0.353
8G	0.329	0.354
	0.329	0.362
	0.338	0.370
	0.338	0.362

亮度组  
Brightness Groups

亮度组 Brightness Group	光通量 <sup>第 20 页 1)</sup> Luminous Flux <sup>1) page 20</sup> $\Phi_v$ (lm)	发光强度 <sup>第 20 页 2)</sup> Luminous Intensity <sup>2) page 20</sup> $I_v$ (mcd)
KY	82.000 ... 97.000	22.400 (典型值) / (typ.)
KZ	97.000 ... 112.000	26.100 (典型值) / (typ.)
LX	112.000 ... 130.000	30.200 (典型值) / (typ.)
LY	130.000 ... 150.000	35.000 (典型值) / (typ.)

注释: 系列类型的标准装运格式包括仅由几个单个亮度组组成的产品族亮度组。单个亮度组不接受订购。

Note: The standard shipping format for serial types includes a family group of only a few individual brightness groups. Individual brightness groups cannot be ordered.

标签上的组名  
Group Name on Label

示例: KY-6P

Example: KY-6P

亮度组 Brightness Group	色度坐标组 Chromaticity Coordinate Group
KY	6P

注释: 每个包装单元/卷带均仅包含一个亮度组。

Note: No packing unit / tape ever contain more than one brightness group.

相对辐射光谱 第 20 页 2)

Relative Spectral Emission<sup>2)</sup> page 20

$V(\lambda) =$  标准视觉曲线 / Standard eye response curve

$\Phi_{rel} = f(\lambda); T_A = 25^\circ\text{C}; I_F = 350 \text{ mA}$

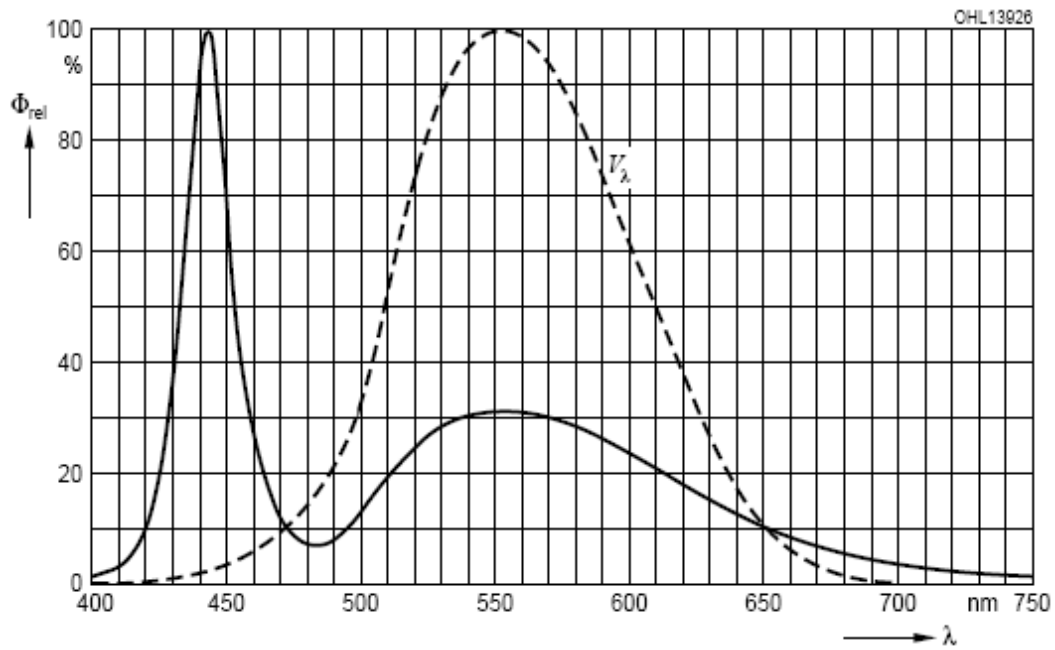

配光曲线 第 20 页 2)

Radiation Characteristic<sup>2)</sup> page 20

$I_{rel} = f(\varphi); T_A = 25^\circ\text{C}$

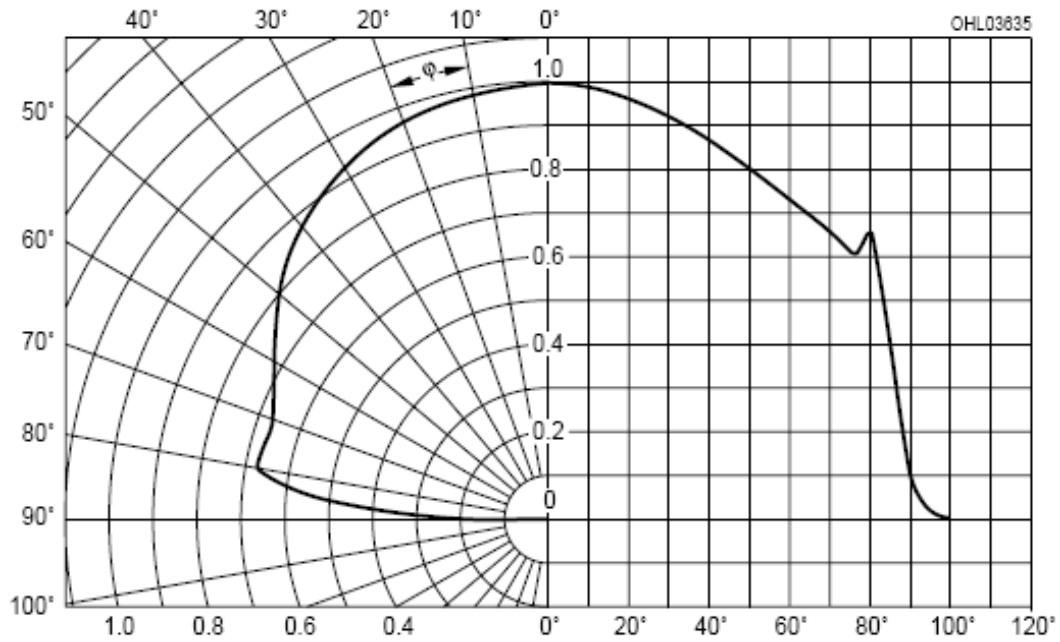

正向电流 第 20 页 2)

Forward Current <sup>2)</sup> page 20

$I_F = f(V_F); T_A = 25^\circ\text{C}$

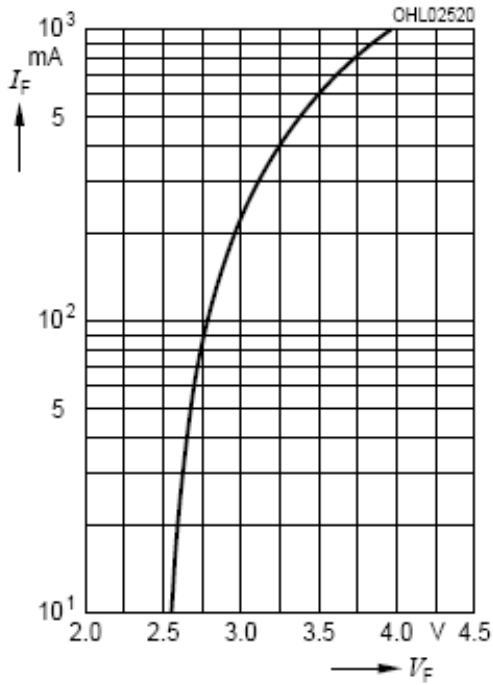

相对光通量 第 23 页 2)、7)

Relative Luminous Flux <sup>2) 7)</sup> page 20

$\Phi_V / \Phi_{V(350\text{ mA})} = f(I_F); T_A = 25^\circ\text{C}$

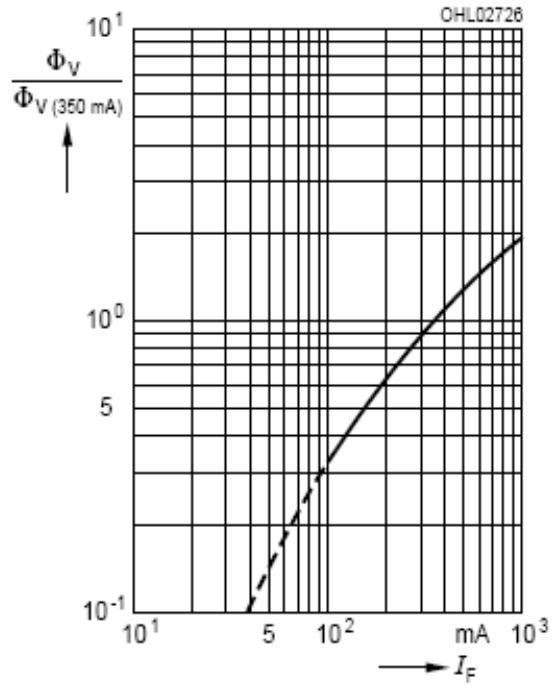

色度坐标偏移 第 20 页 2)

Chromaticity Coordinate Shift <sup>2)</sup> page 20

$x, y = f(I_F); T_A = 25^\circ\text{C}$

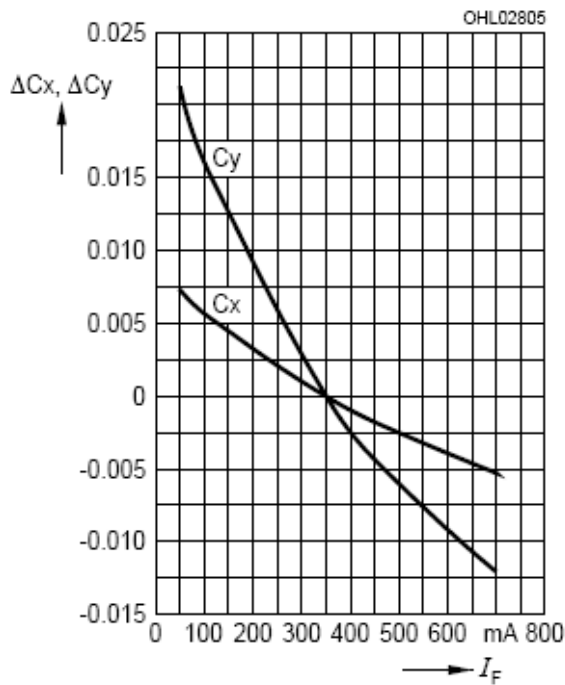

相对正向电压 第 20 页 2)

**Relative Forward Voltage**<sup>2)</sup> page 20

$$\Delta V_F = V_F - V_{F(25^\circ\text{C})} = f(T_j); I_F = 350 \text{ mA}$$

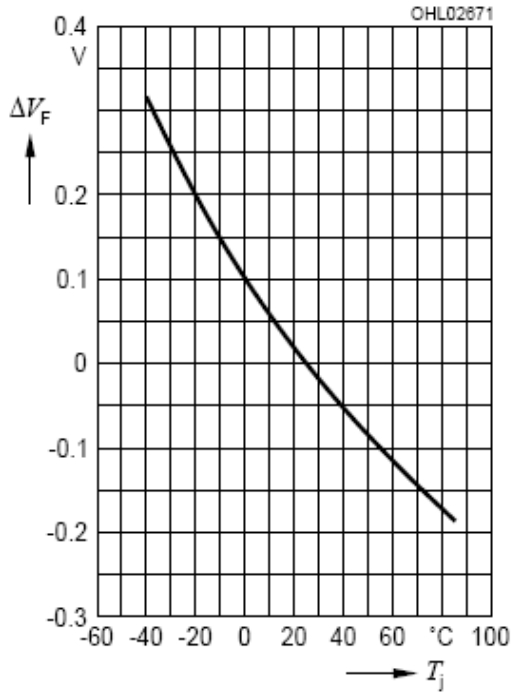

相对光通量 第 20 页 2)

**Relative Luminous Flux**<sup>2)</sup> page 20

$$\Phi_V / \Phi_{V(25^\circ\text{C})} = f(T_j); I_F = 350 \text{ mA}$$

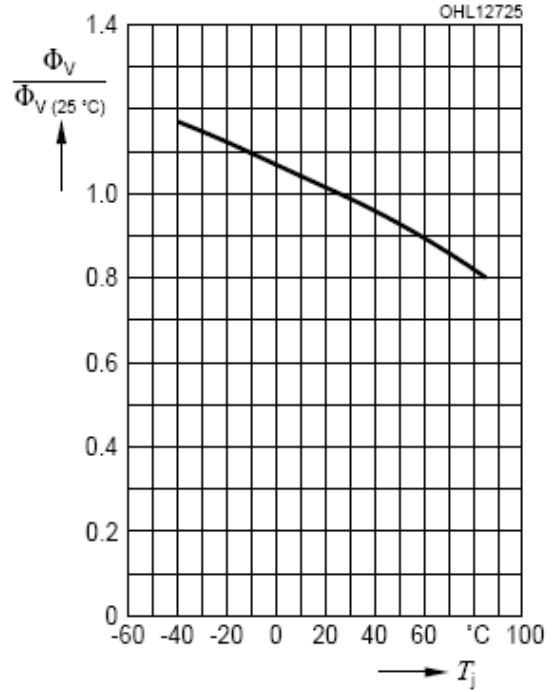

色度坐标偏移 第 20 页 2)

**Chromaticity Coordinate Shift**<sup>2)</sup> page 20

$$x, y = f(T_j); I_F = 350 \text{ mA}$$

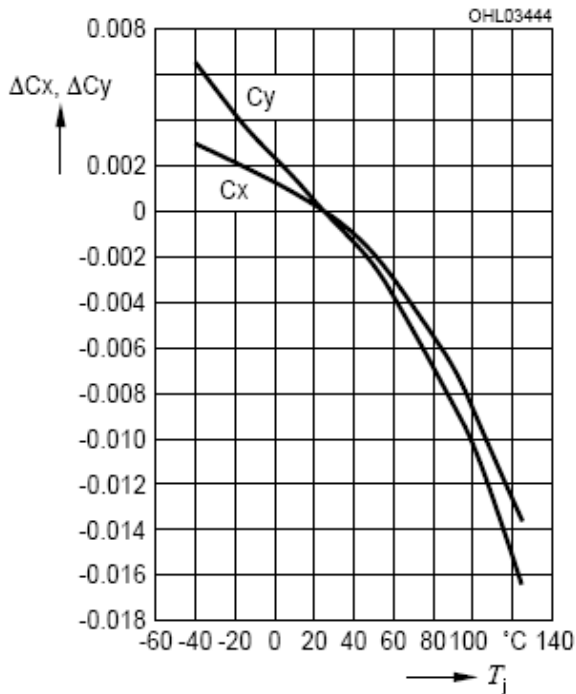

最大容许正向电流  
**Max. Permissible Forward Current**  
 $I_F = f(T_S)$

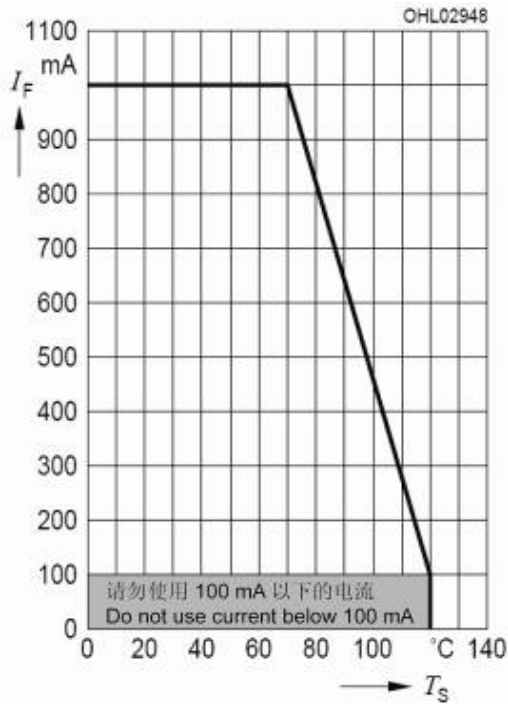

容许脉冲调制能力  $I_F = f(t_p)$   
**Permissible Pulse Handling Capability**  
 占空比  $D =$  参数,  $T_S = 25^\circ\text{C}$   
 Duty cycle  $D =$  parameter,  $T_S = 25^\circ\text{C}$

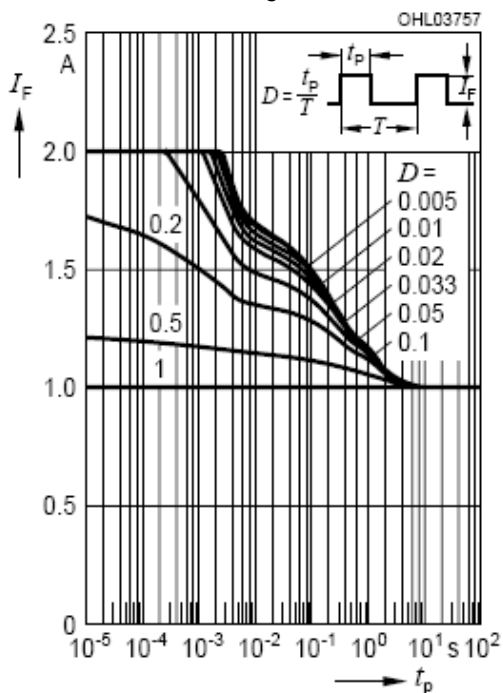

容许脉冲调制能力  $I_F = f(t_p)$   
**Permissible Pulse Handling Capability**  
 占空比  $D =$  参数,  $T_S = 85^\circ\text{C}$   
 Duty cycle  $D =$  parameter,  $T_S = 85^\circ\text{C}$

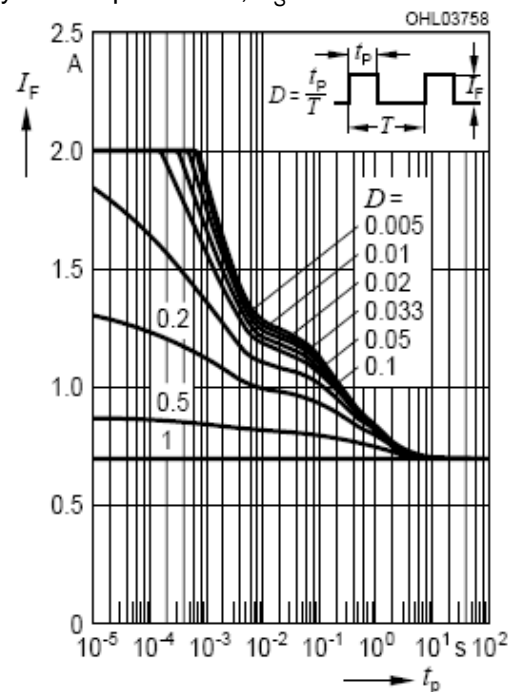

封装略图 (第 20 页 8)  
 Package Outlines (8) page 20

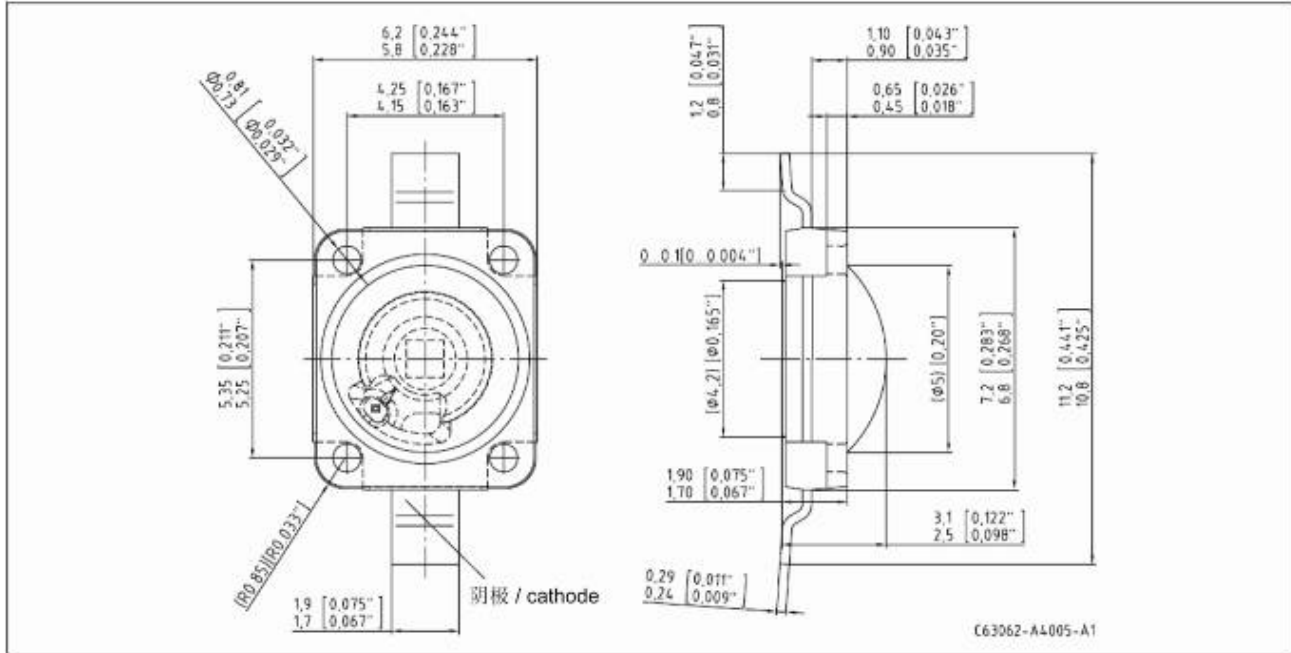

阴极标记  
 Cathode mark:  
 参考重量 / Approx. weight:

标记  
 mark  
 200 mg

卷带封装方式 / 极性和方向 (第 20 页 8)  
 Method of Taping / Polarity and Orientation (8) page 20

包装单元 200/卷, 直径为 180 mm  
 Packing unit 200/reel, ø180 mm

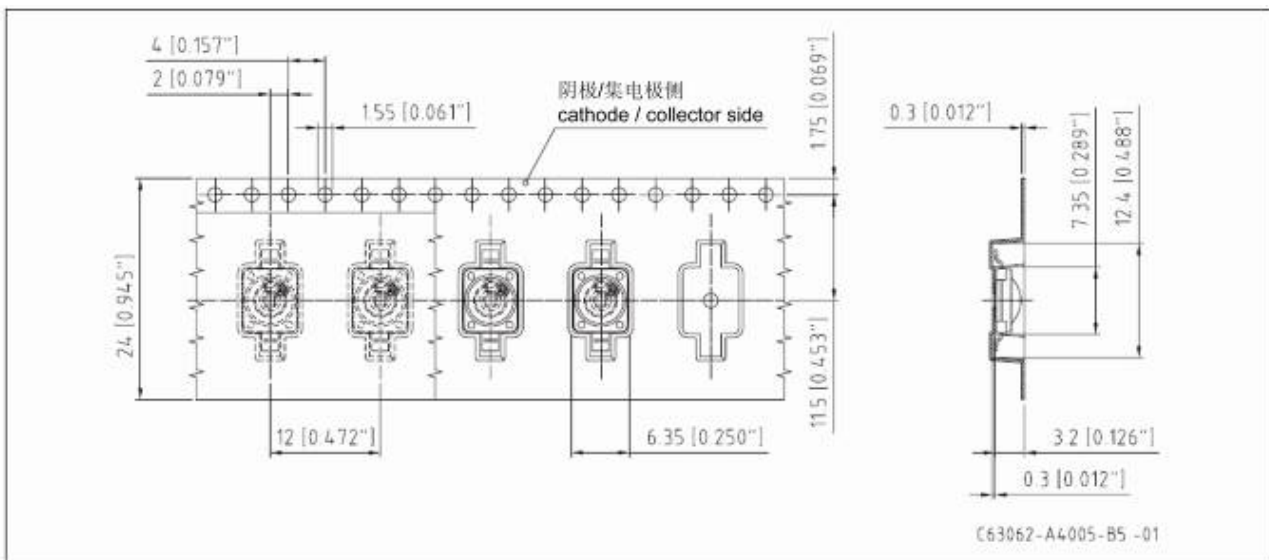

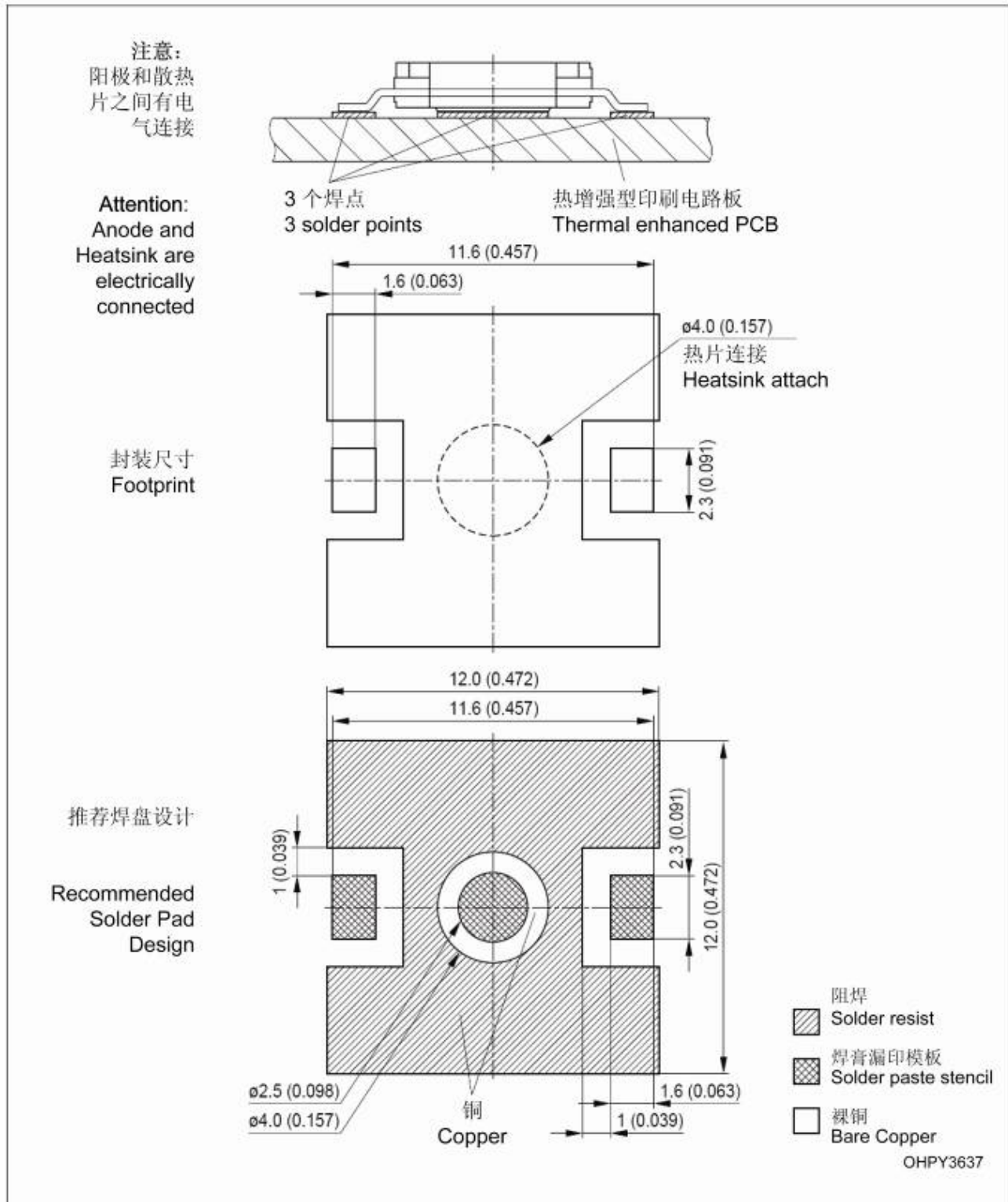

焊接条件

Soldering Conditions

无铅焊接的回流焊接温度曲线简图

Reflow Soldering Profile for lead free soldering

预处理符合 JEDEC 4 级标准

Preconditioning acc. to JEDEC Level 4

(符合 J-STD-020B 标准)

(acc. to J-STD-020B)

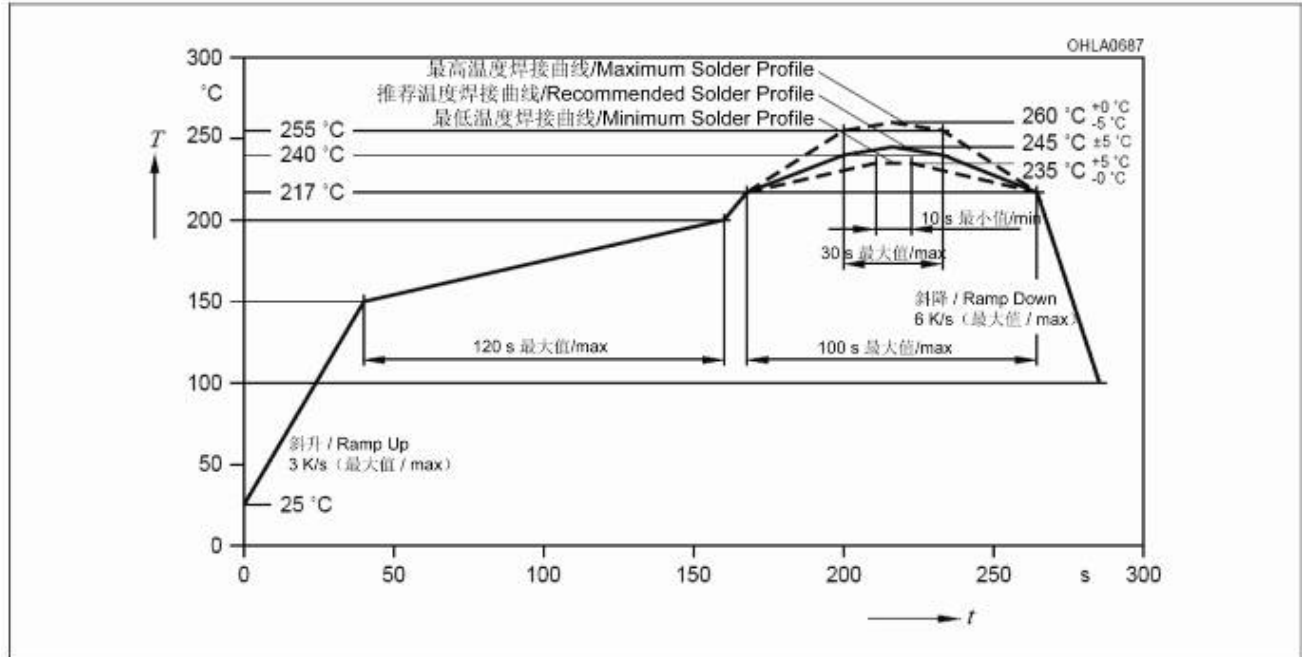

注释： 此封装不适宜超声波清洗

Note: Package not suitable for ultra sonic cleaning

条形码 — 产品标签 (BPL)  
Barcode-Product-Label (BPL)

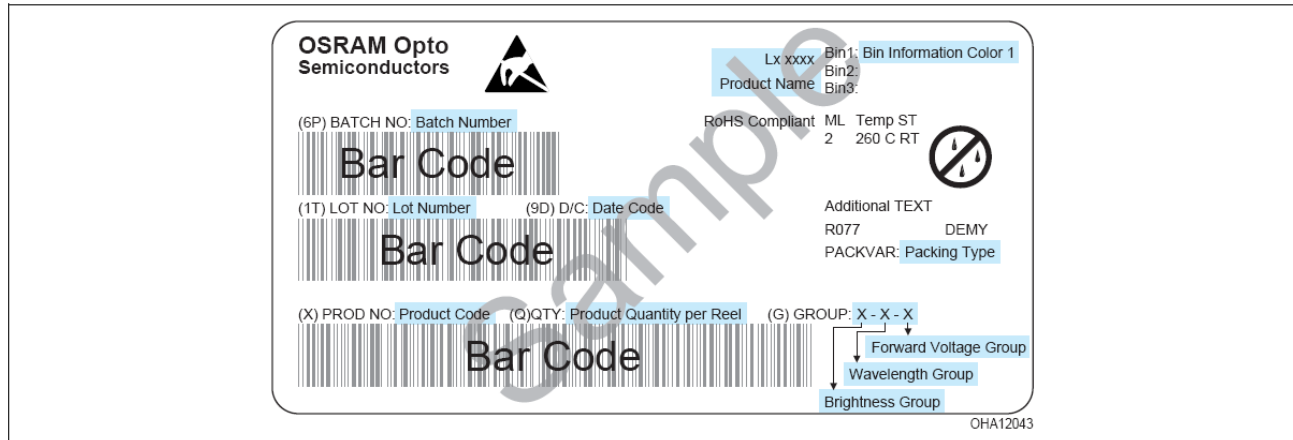

卷带和卷盘  
Tape and Reel

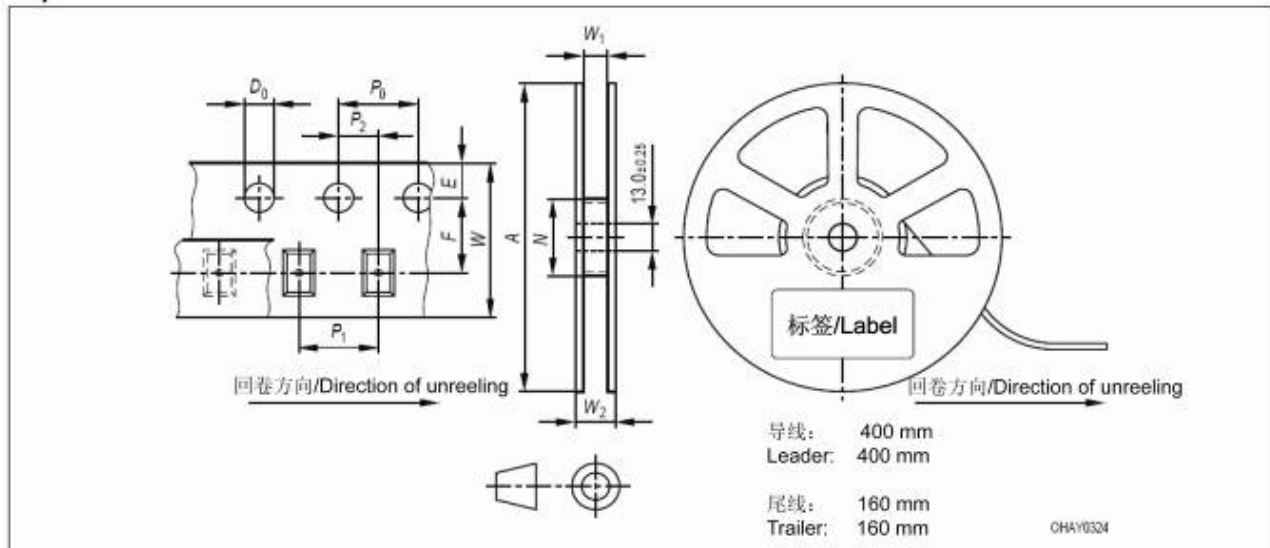

卷带尺寸 (单位: mm (英寸)) / Tape dimensions in mm (inch)

W	$P_0$	$P_1$	$P_2$	$D_0$	E	F
$24^{+0.3}_{-0.1}$	$4 \pm 0.1$ ( $0.157 \pm 0.004$ )	$8 \pm 0.1$ ( $0.315 \pm 0.004$ )	$2 \pm 0.1$ ( $0.079 \pm 0.004$ )	$1.5 + 0.1$ ( $0.059 + 0.004$ )	$1.75 \pm 0.1$ ( $0.069 \pm 0.004$ )	$11.5 \pm 0.1$ ( $0.453 \pm 0.004$ )

卷盘尺寸 (单位: mm (英寸)) / Reel dimensions in mm (inch)

A	W	$N_{min}$	$W_1$	$W_2_{max}$
180 (7)	24 (0.945)	60 (2.362)	$24.4 + 2$ ( $0.961 + 0.079$ )	30.4 (1.197)

干式充填工艺和材料  
**Dry Packing Process and Materials**

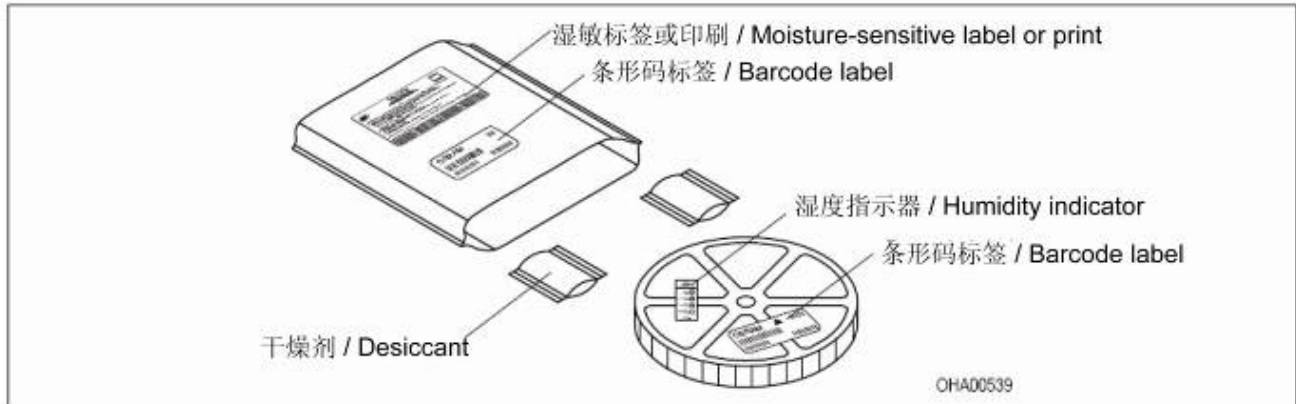

注释： 湿敏产品包装在装有干燥剂和湿度卡的干燥袋子中。  
 关于干式充填的详细信息，请参阅网站资料和简明版产品目录中“干式充填”标题下的“卷带和卷盘”章节。您还可以找到 JEDEC 等规范性参考。

Note: Moisture-sensitive product is packed in a dry bag containing desiccant and a humidity card.  
 Regarding dry pack you will find further information in the internet and in the Short Form Catalog in chapter “Tape and Reel” under the topic “Dry Pack”. Here you will also find the normative references like JEDEC.

运输包装和材料  
**Transportation Packing and Materials**

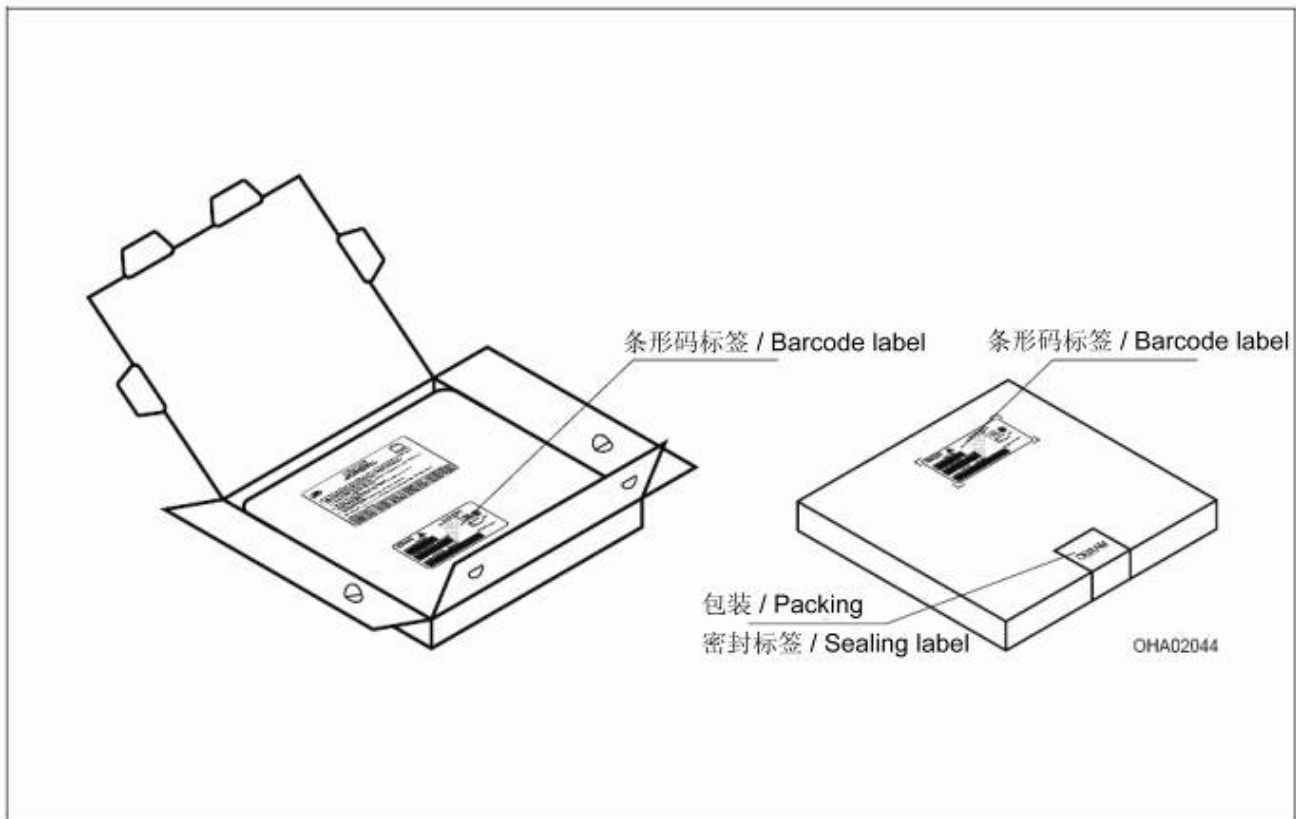

**修订记录 / Revision History: 2009-06-19**

先前版本 / Previous Version: 2009-06-19

页码 Page	更改内容（自上次修订后的更改） Subjects (major changes since last revision)	更改日期 Date of change
12	变更图表容许脉冲调制能力 Diagrams Permissible Pulse Handling Capability changed	2008-02-27
2, 8	新增订购代码 New ordering codes added	2008-08-05
1, 4	更新典型亮度 typ. brightness updated	2008-08-12
2	更正订购代码说明 Ordering code description corrected	2008-08-26
2	更新订购代码 Ordering codes updated	2009-03-16
6	更正图表色度坐标组 Diagram chromaticity coordinate groups corrected	2009-03-31
4	新增热阻 $R_{th JS}$ （典型值） Thermal resistance $R_{th JS}$ (typ.) added	2009-04-22
4	OS-IN-2009-020（降低正向电压最大值） OS-IN-2009-020 (Forward voltage max reduced)	2009-06-16
13	更新封装略图、卷带封装方式/极性和方向 Package Outlines and Method of Taping / Polarity and Orientation	2009-06-19
2, 8	更新订购代码 ordering codes updated	2009-10-19
1	更新典型光通量 typical Luminous Flux updated	2009-10-19
1, 4	更新光效 optical efficiency updated	2009-10-19

由于 IEC 60825 标准计划取消 LED 部分，所以本产品根据 CIE S009/E:2002 标准（“灯和灯系统的光生物安全性”）进行眼睛安全评估。

在该 CIE 标准的风险分组系统中，本数据表中指定的 LED 属于“低风险”组（与接触时间为 100 秒的可见光谱范围内的装置相关）。在实际环境（包括接触时间、瞳孔、观察距离）中，认为这些装置对人眼没有危害。

但是，作为原则问题，必须提及强烈光源具有致盲效应，因此很可能发生二次曝光。直视其他明亮光源（如车前灯）时也是如此，视敏度可能会暂时下降，也可能出现余像，从而导致困扰、烦恼、视障甚至意外事故，具体取决于当时的情况。

Due to the planned cancellation of the LED from IEC 60825, the evaluation of eye safety occurs according to the standard CIE S009/E:2002 ("photobiological safety of lamps and lamp systems").

Within the risk grouping system of this CIE standard, the LEDs specified in this data sheet fall into the "low risk" group (relating to devices in the visible spectrum with an exposure time of 100 s). Under real circumstances (for exposure time, eye pupils, observation distance), it is assumed that no endangerment to the eye exists from these devices.

As a matter of principle, however, it should be mentioned that intense light sources have a high secondary exposure potential due to their blinding effect. It is also true when viewing other bright light sources (e.g. headlights), temporary reduction in visual acuity and afterimages can occur, leading to irritation, annoyance, visual impairment, and even accidents, depending on the situation.

---

**专利列表 / Patent List****专利号 / Patent No.**

US 6 066 861  
US 6 277 301  
US 6 245 259

---

**请注意!**

元件类型的描述性信息不应被视作对特性的保证。

欧司朗保留交货条件和变更设计的权力。因技术需要，元件可能包含危险物质。如果对类型信息有疑问，请联系我们的销售部门。

如需打印或下载，请到公司网站寻找最新版本。

**Attention please!**

The information describes the type of component and shall not be considered as assured characteristics.

Terms of delivery and rights to change design reserved. Due to technical requirements components may contain dangerous substances. For information on the types in question please contact our Sales Organization.

If printed or downloaded, please find the latest version in the Internet.

**封装**

请联系您所熟悉的物资回收公司。我们也可以帮助您联系最近的销售办事处。如果您已对包装材料进行分类，我们将根据协议进行回收，所产生的运输费用须由您承担。对于未经分类即退回本公司或我们没有责任接受的包装材料，我们将开具发票由您支付因此产生的一切费用。

**Packing**

Please use the recycling operators known to you. We can also help you – get in touch with your nearest sales office. By agreement we will take packing material back, if it is sorted. You must bear the costs of transport. For packing material that is returned to us unsorted or which we are not obliged to accept, we shall have to invoice you for any costs incurred.

**生命支持装置或系统所采用的元件必须获取该目的明确授权!** 仅当获得欧司朗公司的明确书面许可时，方可将关键元件第 20 页 9) 用于生命支持装置或系统第 20 页 10)。

**Components used in life-support devices or systems must be expressly authorized for such purpose!** Critical components<sup>9) page 20</sup> may only be used in life-support devices or systems<sup>10) page 20</sup> with the express written approval of OSRAM OS.

**备注:**

- 1) 亮度组的测试电流脉冲时长为 25 ms，容差为  $\pm 11\%$ 。
- 2) 由于 LED 制造工艺的条件特殊，典型数据或计算得出的技术参数相关性仅能反映统计数字，而不等同于各产品的实际参数，它们可能与典型数据和计算得出的相关性或典型特征线数据不同。如果需要（如由于技术改进），这些典型数据将有所变更，恕不另行通知。
- 3) -
- 4) -
- 5) 色度坐标组的测试电流脉冲时长为 25 ms，容差为  $\pm 0.01$ 。
- 6) 正向电压的测试电流脉冲时长为 1 ms，容差为  $\pm 0.1$  V。
- 7) 在虚线范围内，单个包装单元内的不同 LED 之间的明暗差别会更大。
- 8) 尺寸单位指定为：mm（英寸）
- 9) 关键元件指用在生命支持装置或系统中、一旦发生故障即会引起装置或系统故障或影响其安全性或有效性的元件。
- 10) 生命支持装置或系统拟用于 (a) 植入人体或 (b) 支持和/或维持人的生命。如果发生故障，即会威胁使用者的健康和生命。

**Remarks:**

- 1) Brightness groups are tested at a current pulse duration of 25 ms and a tolerance of  $\pm 11\%$ .
- 2) Due to the special conditions of the manufacturing processes of LED, the typical data or calculated correlations of technical parameters can only reflect statistical figures. These do not necessarily correspond to the actual parameters of each single product, which could differ from the typical data and calculated correlations or the typical characteristic line. If requested, e.g. because of technical improvements, these typ. data will be changed without any further notice.
- 3) -
- 4) -
- 5) Chromaticity coordinate groups are tested at a current pulse duration of 25 ms and a tolerance of  $\pm 0.01$ .
- 6) Forward voltages are tested at a current pulse duration of 1 ms and a tolerance of  $\pm 0.1$  V.
- 7) In the range where the line of the graph is broken, you must expect higher brightness differences between single LEDs within one packing unit.
- 8) Dimensions are specified as follows: mm (inch).
- 9) A critical component is a component used in a life-support device or system whose failure can reasonably be expected to cause the failure of that life-support device or system, or to affect its safety or the effectiveness of that device or system.
- 10) Life support devices or systems are intended (a) to be implanted in the human body, or (b) to support and/or maintain and sustain human life. If they fail, it is reasonable to assume that the health and the life of the user may be endangered

欧司朗光电半导体有限公司出版  
 德国雷根斯堡莱布尼茨大街 4 号 D-93055  
[www.osram-os.com](http://www.osram-os.com)  
 © 保留所有权利。

Published by  
**OSRAM Opto Semiconductors GmbH**  
 Leibnizstrasse 4, D-93055 Regensburg  
[www.osram-os.com](http://www.osram-os.com)  
 © All Rights Reserved.

EU RoHS and China RoHS compliant product



此产品符合欧盟 RoHS 指令的要求；  
 按照中国的相关法规和标准，不含有毒有害物质或元素。